

User's Manual

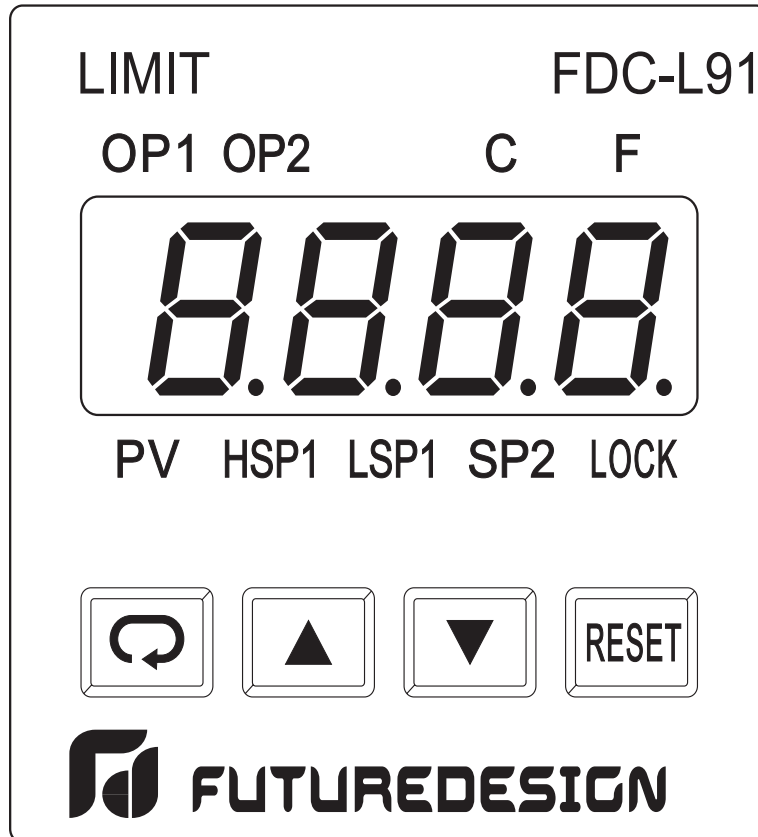

LIMIT L91

Microprocessor Based Limit Controller

UM - L91 September 2023

Warning Symbol

This  Symbol calls attention to an operating procedure, practice, or the like, which, if not correctly performed or adhered to, could result in personal injury or damage to or destruction of part or all of the product and system. Do NOT proceed beyond a warning symbol until the indicated conditions are fully understood and met.

Use the Manual

- Installers Read Chapter 1, 2
- System Designer Read All Chapters
- Expert User Read Page 12

NOTE:

It is strongly recommended that a process should incorporate a LIMIT like L91 which will shut down the equipment at a preset process condition in order to preclude possible damage to products or system.

Information in this user's manual is subject to change.
without notice.

This manual is applicable for L91 units with software version
1.9 and later.

Copyright a March 2006, Future Design Controls, all rights reserved. No part of this publication may be reproduced, transmitted, transcribed or stored in a retrieval system, or translated into any language in any form by any means without the written permission of Future Design Controls.

Contents

	Page No		Page No
Chapter 1 Overview		3-4 PV Shift	35
1-1 General.....	5	3-5 Digital Filter	35
1-2 Ordering Code.....	6	3-6 Process Alarms	36
1-3 Programming Port.....	7	3-7 RS-485 Communication	37
1-4 Keys and Display.....	7	3-8 Display Mode.....	38
1-5 Menu Overview.....	12	3-9 Signal Conditioner DC Power Supply	38
1-6 Limit Control Operation	13	3-10 Remote Reset.....	40
1-7 Parameter Descriptions	16	3-11 Remote Lock.....	40
		3-12 Limit Annunciator.....	41
Chapter 2 Installation		Chapter 4 Applications	
2-1 Unpacking.....	22	42
2-2 Mounting.....	22	Chapter 5 Calibration	
2-3 Wiring Precautions	23	43
2-4 Power Wiring	25	Chapter 6 Specifications	
2-5 Sensor Installation Guidelines	25	47
2-6 Thermocouple Input Wiring	26		
2-7 RTD Input Wiring	27		
2-8 Linear DC Input Wiring	28		
2-9 Event Input Wiring.....	29		
2-10 Output 1 Wiring.....	30		
2-11 Output 2 Wiring.....	31		
2-12 RS 485	32		
2-13 Ma Retransmission.....	32		
Chapter 3 Programming			
3-1 Process Input	33		
3-2 Limit Control.....	34		
3-3 Setpoint Range	34		

Figures & Tables

	Page No
Figure 1-1 Programming Port Location	7
Figure 1-2 Front Panel Display	8
Figure 1-3 Power Up Sequence	10
Figure 1-4 High Limit Operation	13
Figure 1-5 Low Limit Operation	14
Figure 1-6 High/Low Limit Operation	15
Figure 2-1 Mounting Diagram	23
Figure 2-2 Lead Termination	24
Figure 2-3 Rear Terminal Connection Diagram	24
Figure 2-4 Power Supply Connections	25
Figure 2-5 Thermocouple Input Wiring	27
Figure 2-6 RTD Input Wiring	27
Figure 2-7 Linear Voltage Input Wiring	28
Figure 2-8 Linear Current Input Wiring	28
Figure 2-9 Event Input Wiring	29
Figure 2-10 Output 1 Wiring	30
Figure 2-11 Output 2 Wiring	31
Figure 2-12 RS-485 Wiring	32
Figure 3-1 Conversion of Linear Process Input	33
Figure 3-2 Filter Characteristics	35
Figure 3-3 Normal Process Alarm	37
Figure 3-4 Latching Process Alarm	37
Figure 3-5 DC Power Supply Application	39
Figure 3-6 Remote Reset Application	40
Figure 3-7 Remote Lock Application	40
Figure 4-1 Over Temperature Protection w/ Remote Reset	42
Figure 5-1 Flow chart for Manual Calibration	44
Figure 5-2 Cold Junction Calibration Setup	45
Figure 5-3 RTD Calibration	46
Table 1-1 Display Form of Characters	9
Table 6-1 Input Characteristics	48

Chapter 1 Overview

1-1 General

The limit control **L91** is a microprocessor based high or low limit safety device with a latching output. The relay contacts open if an abnormal condition during the process is higher than the high limit set point or lower than the low limit set point.

The unit is powered by 90-264 VAC or an optional 11-26 VAC/VDC power supply. It incorporates a 2 amp. form C relay for limit control, a universal input which is fully programmable for RTD PT100, thermocouple types J, K, T, E, B, R, S, N, L, 0~60mVolt, Volt* and Milliamps*. An optional second output is available for one of the following functions: alarm output, RS-485 communication, MA output, DC power supply output, limit annunciator output and event input. Alternative output options include; relay, SSR drive, Triac and Ma for retransmission. All mutually exclusive.

The input signal is digitized by using a 18-bit A to D converter. Its fast sampling rate (5 times/second) allows the L91 to respond quickly to input changes.

Digital communication RS-485 is available as an additional option. This option allows L91 to be integrated with supervisory control system. An alarm output is another option. A variety of alarm function and alarm modes can be programmed for a specific application. The DC power supply output option is used for an external sensor or transmitter. The event input option can be programmed for remote reset or remote lock signal input. The limit annunciator option can be used to energize an external audible alarm when limit is reached. Ma retransmission option of Process variable or setpoint is also available.

Two kinds of method can be used to program L91. 1. use keys on front panel to program the unit manually, 2. Use a PC and setup software to program the unit via RS-485 port.

High accuracy, maximum flexibility, fast response and simple **user friendly prompts** are the main features of L91.

NOTE: * Volt and Milliamp Inputs are NOT FM Approved.

1-2 Ordering Code

L91 — 1 2 3 4

Power Input

- 4: 90 - 264 VAC, 50/60 HZ
- 5: 11 - 26 VAC or VDC
- 9: Special Order

Signal Input

- 1: Standard Input
Thermocouple: J, K, T, E, B,
R, S, N, L
RTD: PT100 DIN, PT100 JIS
mV: 0~60 mV
- 2: Voltage: 0-1 V *
- 3: Voltage : 0-10 V *
- 4: Current: 0-20mA/4-20mA *
- 5: Voltage: 0-5, 1-5 V *

Example

Standard Model:

L91-4110

90-264 VAC Operation

- Input: Standard Input
- Output 1: Relay
- Option: None

Output 1

- 1: Form C relay rated
2A/240VAC
- 2: Pulsed voltage to
drive SSR, 5V/30mA
- 6: Triac Output
1A / 240VAC,SSR
- 9: Special order

Option

- 0: None
- 1: Form A Relay 2A/240VAC
- 2: SSR Drive 5VDC @ 30 ma
- 6: Triac Output, 1A / 240VAC, SSR
- 7: Isolated 20V / 25mA DC Supply
- 8: Isolated 12V / 40 mA DC Supply
- 9: Isolated 5V / 80mA DC Supply
- A: RS-485
- B: Event input
- C: SSR Drive 14VDC @ 40 ma
- D: Retransmit 4/20, 0/20 Ma
- E: Retransmit 1/5, 0/5 VDC
- F: Retransmit 0/10 VDC
- H: Special order

Accessories

- OM94-6 = Isolated 1A / 240VAC Triac Output Module (SSR)
- OM94-7 = 14VDC/40 ma SSR Drive module
- DC 94-1 = Isolated 20V / 25mA DC Output Power Supply
- DC 94-2 = Isolated 12V / 40mA DC Output Power Supply
- DC 94-3 = Isolated 5V / 80mA DC Output Power Supply
- CM 96-1 = Isolated RS-485 Interface Module
- CM 96-3 = Isolated 4/20, 0/20 MA Retransmission Output Module
- CM 96-4 = Isolated 1/5, 0/5 VDC Retransmission Output Module
- CM 96-5 = Isolated 0/10 VDC Retransmission Output Module
- EI96-1 = Event Input Module

NOTE: * Volt and Milliamp Inputs are NOT FM Approved.

Related Products

P11A = Hand-held Programmer for L91,C91 Series Controller

SNA10A = Smart Network Adaptor for Third Party Software,
Converts 255 channels of RS-485 or RS-422 to
RS-232 Network

SNA10B = Smart Network Adaptor for FD-Net Software, Converts
255 channels of RS-485 or RS-422 to RS-232 Network

1-3 Programming Port

Programming Port

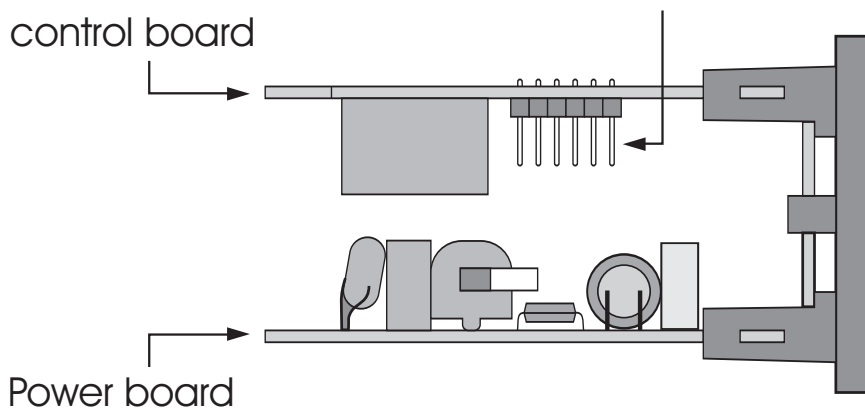

Open the housing
Top view of L91

Figure 1-1 Programming
Port Location

Note: The programming port is used for off-line setup and calibration procedures only. Do not attempt to make any connection to these jumpers when the unit is on-line. Port is for bench setup only.

1-4 Keys and Display

KEYPAD OPERATION

SCROLL KEY 

This key is used to:

1. Select a setpoint to be displayed.
2. Select a parameter to be viewed or adjusted.
3. Advance display from a parameter code to the next parameter code

ENTER KEY  4 seconds, 8 seconds

Press the scroll key for 4 seconds the display will enter the setup menu. Press this key for 8 seconds to enter the calibration mode.

UP KEY 

This key is used to increase the selected parameter value during the lock indicator is off.

DOWN KEY 

This key is used to decrease the selected parameter value during the lock indicator is off.

RESET KEY 

This key is used to:

1. Reset the limit condition after the process is within the limit.
2. Revert the display to the normal display.
3. Reset the latching alarm.
4. Reset the limit annunciator.

Note: If the RESET key is left pressed, only ONE reset operation will occur. If the unit subsequently goes into a state where reset is required again, the RESET key (or remote reset contacts) must be released (opened) and pressed (closed) again.

UNLOCK KEY  4 seconds

Press the RESET key for 4 seconds to enable up/down key function, and the lock indicator led will be extinguished.

However, this function is disabled when remote lock is selected for EIFN (Event input function). **See section 3-16.**

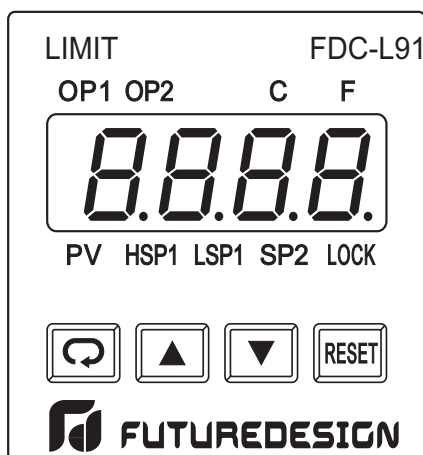

INDICATORS

Op1: Output 1 status indicator

OP2: Output 2 status indicator

C: Degree C indicator

F: Degree F indicator

PV: Process value

HSP1: High limit set point 1

LSP1: Low limit set point 1

SP2: Set point 2 for output 2

LOCK: Lock status indicator

Figure 1-2 Front Panel Display

DISPLAY FORM

Table 1-1 Display Form of Characters

A	<i>A</i>	E	<i>E</i>	I	<i>I</i>	N	<i>n</i>	S	<i>S</i>	X	
B	<i>b</i>	F	<i>F</i>	J	<i>J</i>	O	<i>o</i>	T	<i>t</i>	Y	<i>y</i>
C	<i>C</i>	G	<i>G</i>	K	<i>K</i>	P	<i>P</i>	U	<i>u</i>	Z	
c	<i>c</i>	H	<i>H</i>	L	<i>L</i>	Q		V	<i>v</i>	?	<i>?</i>
D	<i>d</i>	h	<i>h</i>	M	<i>m</i>	R	<i>r</i>	W		=	<i>=</i>

▴: These characters are displayed differently.

How to display a 5-digit number :

For a number with decimal point the display will be shifted one digit right:

-199.99 will be displayed as -199.9, 4553.6 will be displayed as 4553

For a number without decimal point the display will be divided into two alternating phases:

-19999 will be displayed as:

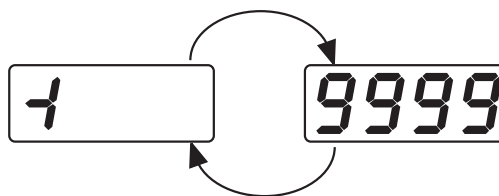

45536 will be displayed as:

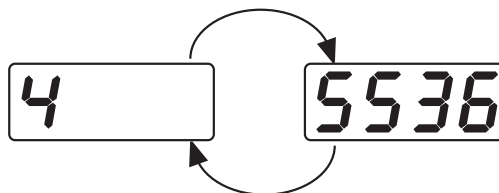

-9999 will be displayed as:

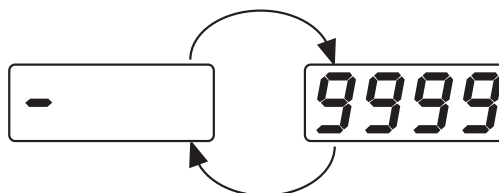

NORMAL DISPLAY

During normal operation, the unit can be configured to display the process value, high limit or low limit set point (HSP1 or LSP1 dependent on OUT1 selection) or the word SAFE.

ABNORMAL DISPLAY

Whenever the process is outside the normal range, the process value will be displayed.

SENSOR BREAK DISPLAY

If a break is detected in the sensor circuit, the display will show:

SEn.b

A-D FAILURE DISPLAY

If failure is detected in the A-D converter circuit, the display will show:

AdEr

POWER UP SEQUENCE

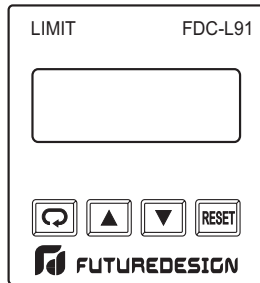

All segments of display and indicators are left off for 0.5 second.

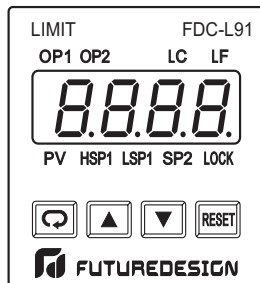

All segments of display and indicators are lit for 1 second.

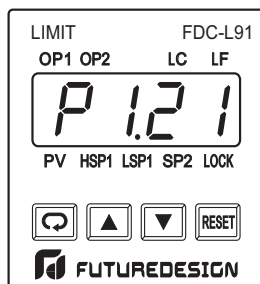

Display program code of the product for 1 second. The left diagram shows program no.1 with version 21.

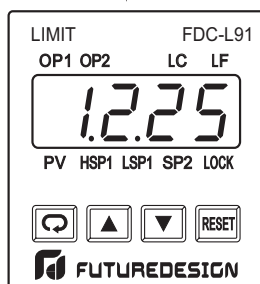

Display Date Code for 1 second. The left diagram shows Year 2001, Month February (2), Date 25'th. This means that the product is produced on February 25'th, 2001. Note that the month code **A** is for **October**, **B** is for **November** and **C** is

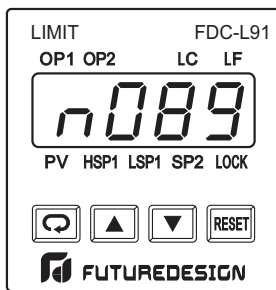

Display the serial number (001 ~999) for 1 second.

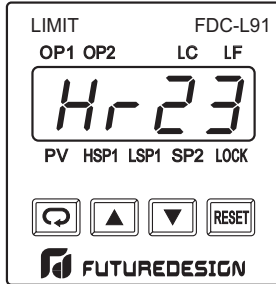

Display the hours used for 2 seconds. The left diagram shows that the unit has been used for 23456.7 hours since production.

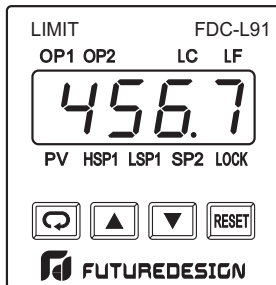
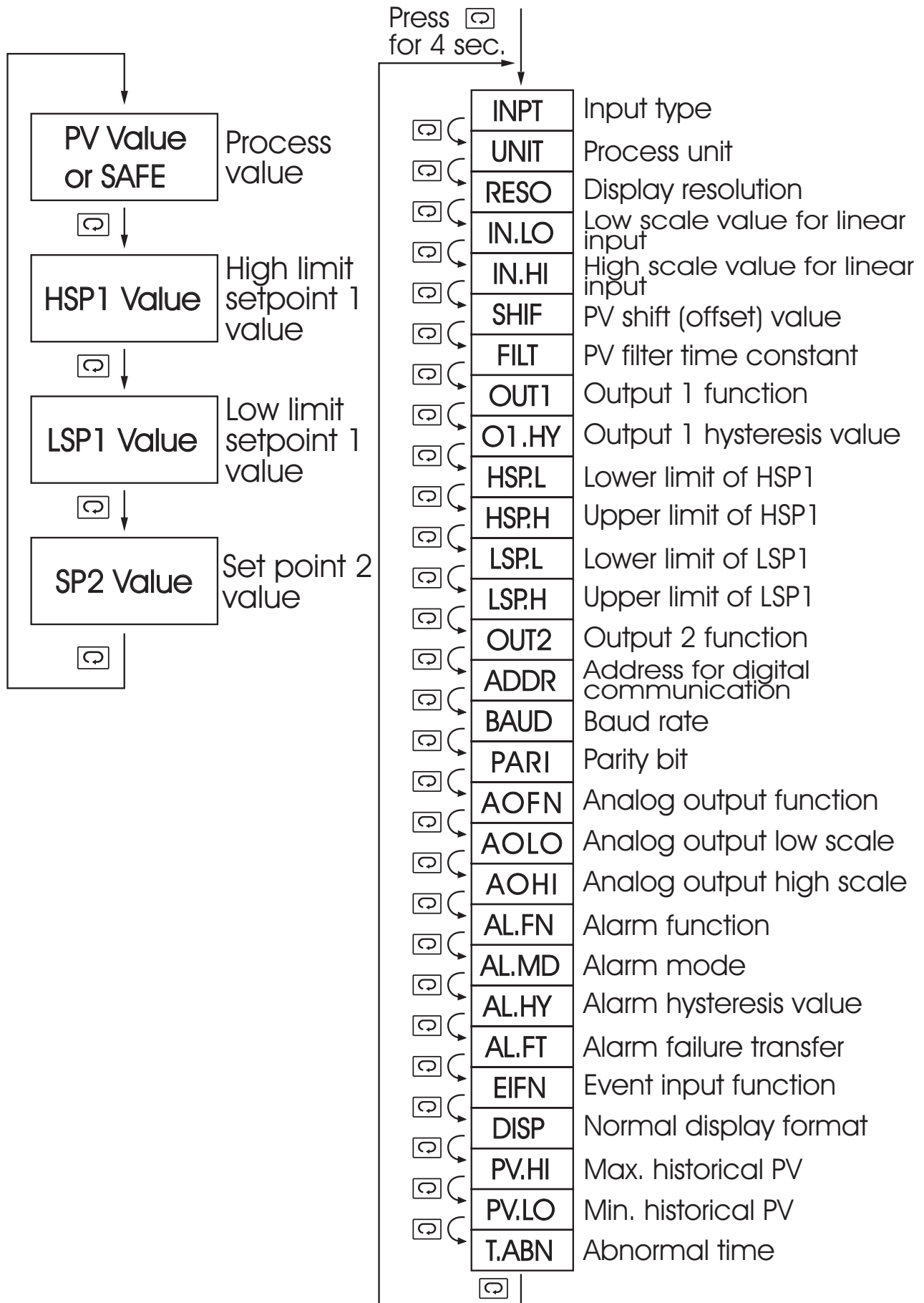



Figure 1-3 Power Up Sequence

1-5 Menu Overview

Setup Mode



Note 1. The flow charts show a complete listing of parameters. For the actual application the number of available parameters is dependent on the setup conditions, and should be less than that shown in the flow charts.

Note 2. Press  key for 4 seconds to enable up/down key function, and the LOCK indicator led will be extinguished.

1-6 Limit Control Operation

HIGH LIMIT OPERATION

If Hi. is selected for OUT1, the unit will perform high limit control. When power is applied the OUT1 relay is de-energized. After 6.5 seconds self-test period, if the process is below the high limit set point (HSP1), the output 1 relay will be energized and OP1 indicator will go off. If the process goes above the high limit set point, the relay will be de-energized, the OP1 indicator will go on and the display will show the process value. After the process falls below the high limit set point and the RESET key is pressed or the remote reset input is applied, the relay will be energized and the OP1 indicator will go off.

NOTE: Hysteresis is safe-sided.

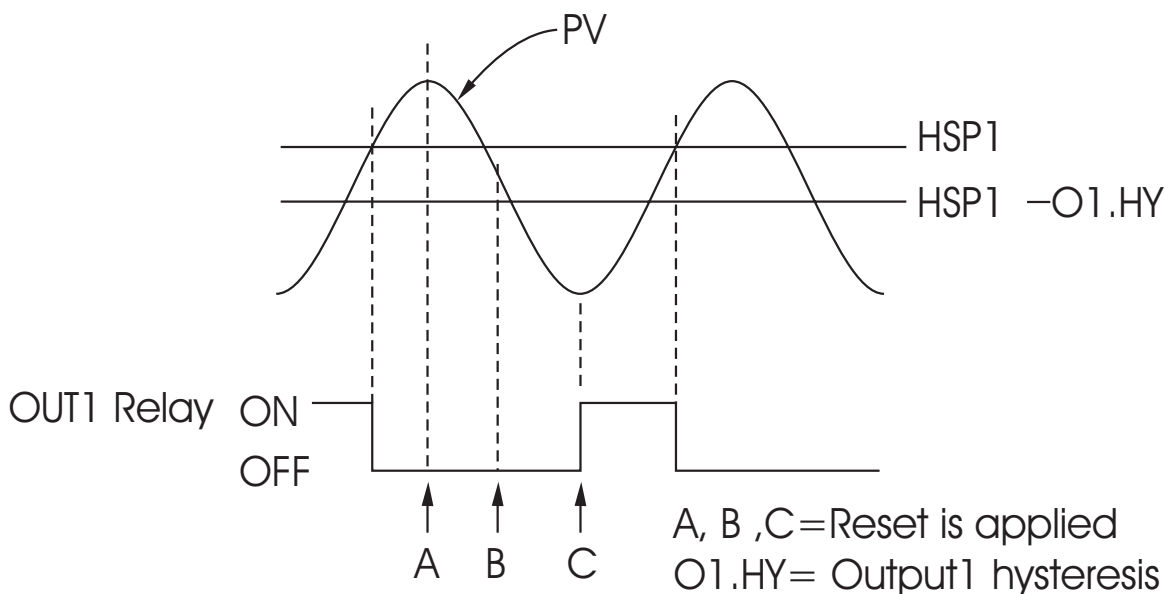

Figure 1-4 High Limit Operation

LOW LIMIT OPERATION

If Lo. is selected for OUT1, the unit will perform low limit control. When power is applied the OUT1 relay is de-energized. After 6.5 seconds self-test period, if the process is above the low limit set point (LSP1), the output 1 relay will be energized and OP1 indicator will go off. If the process goes below the low limit set point, the relay will be de-energized, the OP1 indicator will go on and the display will show the process value. After the process rises above the low limit set point and the RESET key is pressed or the remote reset input is applied, the relay will be energized and the OP1 indicator will go off.

NOTE: Hysteresis is safe-sided.

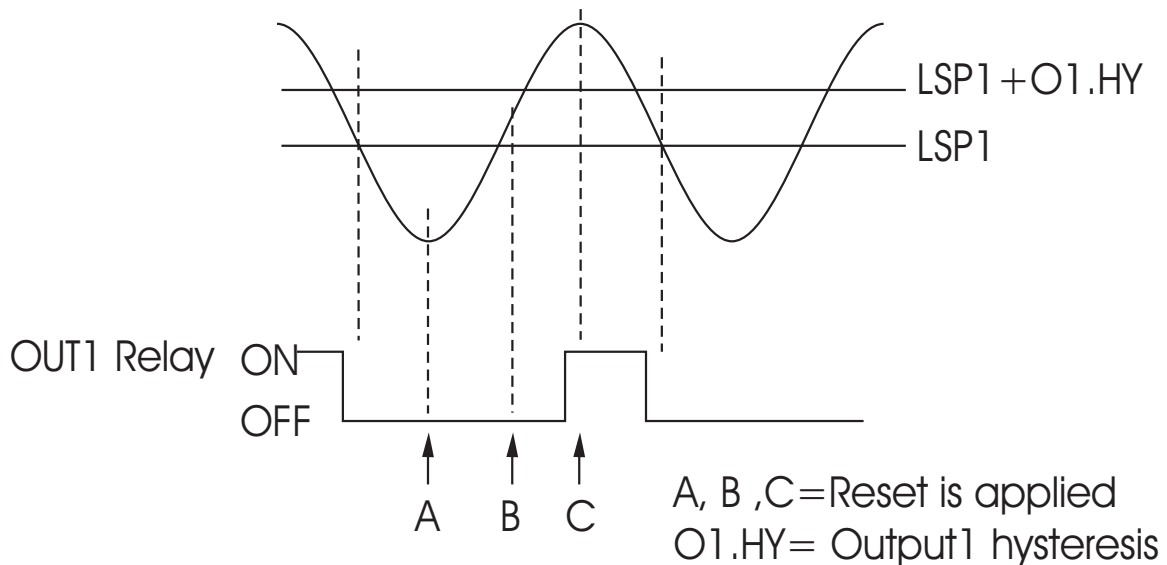

Figure 1-5 Low Limit Operation

HIGH/LOW LIMIT OPERATION

If Hi.Lo is selected for OUT1, the unit will perform high/low limit control. When power is applied the OUT1 relay is de-energized. After 6.5 seconds self-test period, if the process is below the high limit set point (HSP1) and above the low limit set point (LSP1), the output 1 relay will be energized and OP1 indicator will go off. If the process goes above the high limit set point or below the low limit set point, the relay will be de-energized, the OP1 indicator will go on and the display will show the process value. After the process is within the normal operation range, and the RESET key is pressed or the remote reset input is applied, the relay will be energized and the OP1 indicator will go off. NOTE: Hysteresis is safe-sided.

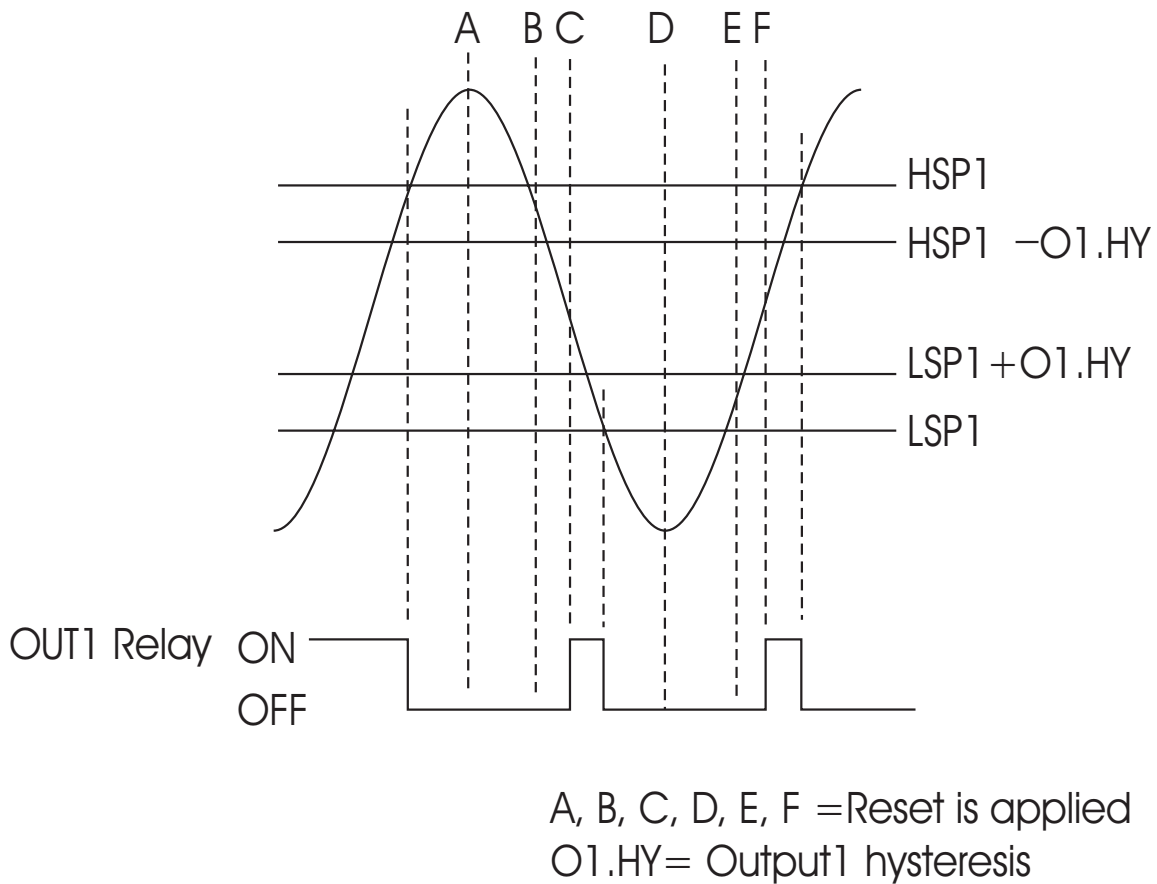

Figure 1-6 High/Low Limit Operation

1-7 Parameter Descriptions

Parameter Notation	Parameter Description	Range	Default Value
HSP1	High Limit Set point 1	Low: HSP.L High: HSP.H	100.0 °C (212.0 °F)
LSP1	Low Limit Set point 1	Low: LSP.L High: LSP.H	0 °C (32.0 °F)
SP2	Set point 2 Value for Output 2	See Table 6-1	90.0 °C (194.0 °F)
INPT	Input Type Selection	0 <i>J_tC</i> : J type thermocouple 1 <i>K_tC</i> : K type thermocouple 2 <i>T_tC</i> : T type thermocouple 3 <i>E_tC</i> : E type thermocouple 4 <i>B_tC</i> : B type thermocouple 5 <i>R_tC</i> : R type thermocouple 6 <i>S_tC</i> : S type thermocouple 7 <i>N_tC</i> : N type thermocouple 8 <i>L_tC</i> : L type thermocouple 9 <i>PT.dn</i> : PT100 ohms DIN curve 10 <i>PT.JS</i> : PT100 ohms JIS curve	1 (0)

Parameter Notation	Parameter Description	Range	Default Value
INPT	Input Type Selection	11 <i>4-20</i> : 4~20 mA linear current* 12 <i>0-20</i> : 0~20 mA linear current* 13 <i>0-60</i> : 0~60 mV linear voltage 14 <i>0-14</i> : 0~1 V linear voltage* 15 <i>0-54</i> : 0~5 V linear voltage* 16 <i>1-54</i> : 1~5 V linear voltage* 17 <i>0-10</i> : 0~10V linear voltage*	1 (0)
UNIT	Process Unit	0 <i>0C</i> : Degree C unit 1 <i>0F</i> : Degree F unit 2 <i>Pu</i> : Process unit	0 (1)
RESO	Display Resolution	0 <i>no.dP</i> : No decimal point 1 <i>1-dP</i> : 1 decimal point 2 <i>2-dP</i> : 2 decimal point 3 <i>3-dP</i> : 3 decimal point	1
IN.LO	Low Scale Value for Linear Input	Low: -19999 High: IN.HI	0

NOTE: Inputs 11, 12, 14, 15, 16, and 17 are NOT FM Approved.

Parameter Notation	Parameter Description	Range	Default Value
IN.HI	High Scale Value for Linear Input	Low: IN.LO High: 45536	100.0
SHIF	PV Shift (offset) Value	Low: -200.0 °C (-360.0 °F) High: 200.0 °C (360.0 °F)	0.0
FILT	PV Filter Time Constant	0 0 : 0 second time constant 1 0.2 : 0.2 second time constant 2 0.5 : 0.5 second time constant 3 1 : 1 second time constant 4 2 : 2 seconds time constant 5 5 : 5 seconds time constant 6 10 : 10 seconds time constant 7 20 : 20 seconds time constant 8 30 : 30 seconds time constant 9 60 : 60 seconds time constant	2
OUT1	Output 1 Function	2 H_i : High limit control 3 L_o : Low limit control 4 H_i.L_o : High/Low limit control	2

Parameter Notation	Parameter Description	Range	Default Value
O1.HY	Output 1 Hysteresis Value	Low: 0.1 High: 10.0 BC (18.0 BF)	0.1
HSP.L	Lower Limit of HSP1	Low: -19999 High: HSP.H	0 C (32.0 F)
HSP.H	Upper Limit of HSP1	Low: HSP.L High: 45536	1000.0 C (1832.0 F)
LSP.L	Lower Limit of LSP1	Low: -19999 High: LSP.H	-100.0 C (-148.0 F)
LSP.H	Upper Limit of LSP1	Low: LSP.L High: 45536	0 C (32.0 F)
OUT 2	Output 2 Function	0 <i>nonE</i> : No function 1 <i>dCPS</i> : DC power supply output 2 <i>Coññ</i> : RS-485 Communication 3 <i>ALñ</i> : Alarm output 4 <i>L_Añ</i> : Limit annunciator 5 <i>E,Fn</i> : Event input 6 <i>4-20</i> : 4-20mA analog retransmission output 7 <i>0-20</i> : 0-20mA analog retransmission output 8 <i>0-1V</i> : 0-1V analog retransmission output 9 <i>0-5V</i> : 0-5V analog retransmission output 10 <i>1-5V</i> : 1-5V analog retransmission output 11 <i>0-10</i> : 0-10V analog retransmission output	4
ADDR	Address Assignment of Digital COMM	Low: 1 High: 255	1
BAUD	Baud Rate of Digital COMM	0 <i>0.3</i> : 0.3 Kbits/s baud rate 1 <i>0.6</i> : 0.6 Kbits/s baud rate	

Parameter Notation	Parameter Description	Range	Default Value
BAUD	Baud Rate of Digital COMM	2 <i>1.2</i> : 1.2 Kbits/s baud rate 3 <i>2.4</i> : 2.4 Kbits/s baud rate 4 <i>4.8</i> : 4.8 Kbits/s baud rate 5 <i>9.6</i> : 9.6 Kbits/s baud rate 6 <i>14.4</i> : 14.4 Kbits/s baud rate 7 <i>19.2</i> : 19.2 Kbits/s baud rate 8 <i>28.8</i> : 28.8 Kbits/s baud rate 9 <i>38.4</i> : 38.4 Kbits/s baud rate	5
PARI	Parity Bit of Digital COMM	0 <i>EVEN</i> : 8 bit even parity 1 <i>odd</i> : 8 bit odd parity 2 <i>none</i> : 8 bit none parity	0
AOFN	Analog Output Function	0 <i>PV</i> : Process value 1 <i>HSP 1</i> : High Limit Set point 1 2 <i>LSP 1</i> : Low Limit Set point 1	0
AOLO	Analog Output Low Scale Value	Low: -19999 High: 45536	0 C (32.0 F)
AOHI	Analog Output High Scale Value	Low: -19999 High: 45536	100.0 C (212.0 F)
ALFN	Alarm function	6 <i>PV.HA</i> : Process value high alarm 7 <i>PV.LA</i> : Process value low alarm	6

Parameter Notation	Parameter Description	Range	Default Value
AL.MD	Alarm mode	0 <i>nor\bar{n}</i> : Normal alarm action 1 <i>Ltch</i> : Latching alarm action	0
AL.HY	Alarm hysteresis value	Low: 0.1 High: 10 BC (18.0 BF)	0.1
AL.FT	Alarm failure transfer	0 <i>off</i> : Alarm output goes off as unit fails 1 <i>on</i> : Alarm output goes on as unit fails	1
EIFN	Event input function	0 <i>nonE</i> : No event function 1 <i>rEst</i> : Remote reset for output 1, output 1 on. 2 <i>Lock</i> : Remote lock for the unit	0
DISP	Normal display format	0 <i>pv</i> : Display process value 1 <i>SP1</i> : Display HSP1 or LSP1 value 2 <i>SAFE</i> : Display the word SAFE	0
PV.HI	Historical Max. value of PV	Low: -19999 High: 45536	Read Only
PV.LO	Historical Min. value of PV	Low: -19999 High: 45536	Read Only
T.ABN	Accumulated time during abnormal condition	Low: 0 High: 6553.5 minutes	Read Only

Chapter 2 Installation



Dangerous voltages capable of causing death are present in this instrument. Before installation or beginning any troubleshooting procedures the power to all equipment must be switched off and isolated. Units suspected of being faulty must be disconnected and removed to a properly equipped workshop for testing and repair. Component replacement and internal must be made by a qualified maintenance person only.



To minimize the possibility of fire or shock hazards, do not expose this instrument to rain or excessive moisture.



Do not use this instrument in areas under hazardous conditions such as excessive shock, vibration, dirt, moisture, corrosive gases or oil. The ambient temperature of the areas should not exceed the maximum rating specified in Chapter 6.

2 - 1 Unpacking

Upon receipt of the shipment remove the unit from the carton and inspect the unit for shipping damage.

If any damage due to transit, report and claim with the carrier.

Write down the model number, serial number, and date code for future reference when corresponding with our service center. The serial number (S/N) and date code (D/C) are labeled on the box and the housing of the unit.

2 - 2 Mounting

Make panel cutout to dimension shown in Figure 2-1.

Install both mounting clamps and insert the housing into panel cutout.

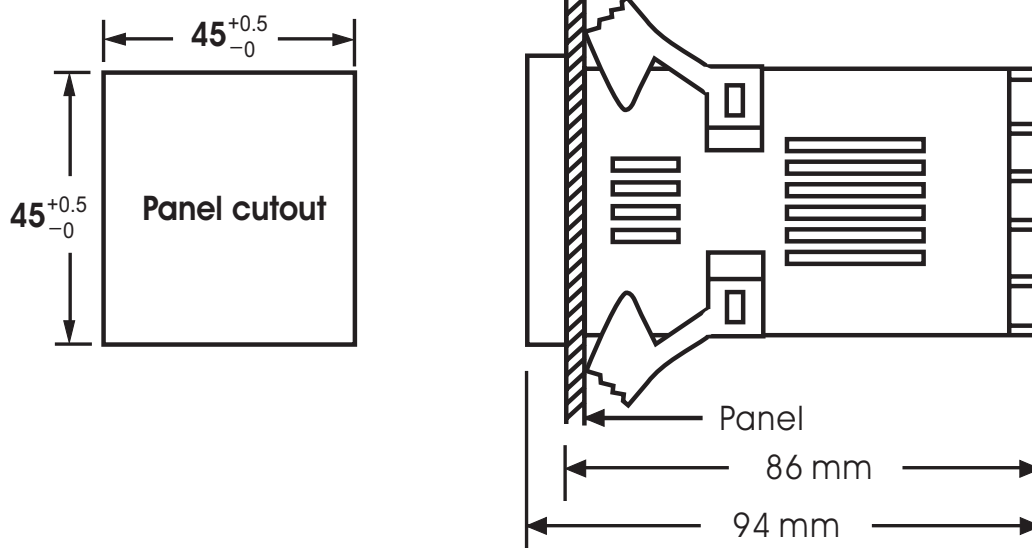

Figure 2-1 Mounting Diagram

2 - 3 Wiring Precautions

- ✱ Before wiring, verify the label for correct model number and options. Switch off the power when checking.
- ✱ Care must be taken to ensure that maximum voltage rating specified on the label are not exceeded.
- ✱ It is recommended that power of these units to be protected by fuses or circuit breakers rated at the minimum value possible.
- ✱ All units should be installed inside a suitably grounded metal enclosure to prevent live parts being accessible from human hands and metal tools.
- ✱ All wiring must conform to appropriate standards of good practice and local codes and regulations. Wiring must be suitable for maximum voltage, current, and temperature rating of the system.
- ✱ Take care not to over-tighten the terminal screws.

- * Unused control terminals should not be used as jumper points as they may be internally connected, causing damage to the unit.
- * Verify that the ratings of the output devices and the inputs as specified in Chapter 6 are not exceeded.
- * Electric power in industrial environments contains a certain amount of noise in the form of transient voltage and spikes. This electrical noise can enter and adversely affect the operation of microprocessor-based controls. For this reason we strongly recommend the use of shielded thermocouple extension wire which connects the sensor to the unit. This wire is a twisted-pair construction with foil wrap and drain wire. The drain wire is to be attached to earth ground at the sensor end only.

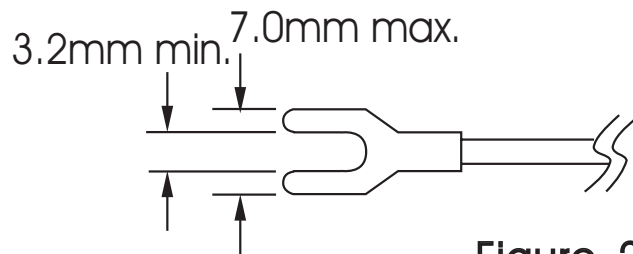

Figure 2-2 Lead Termination

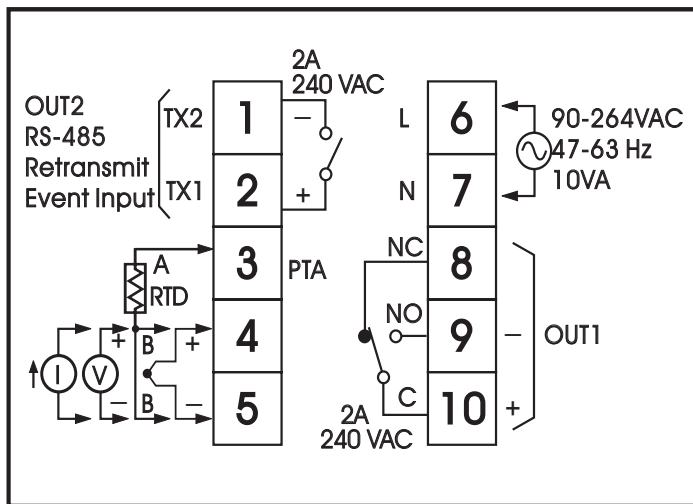

Figure 2-3 Rear Terminal Connection Diagram

2-4 Power Wiring

The unit is supplied to operate at 11-26 VAC / VDC or 90-264VAC. Check that the installation voltage corresponds with the power rating indicated on the product label before connecting power to the unit.

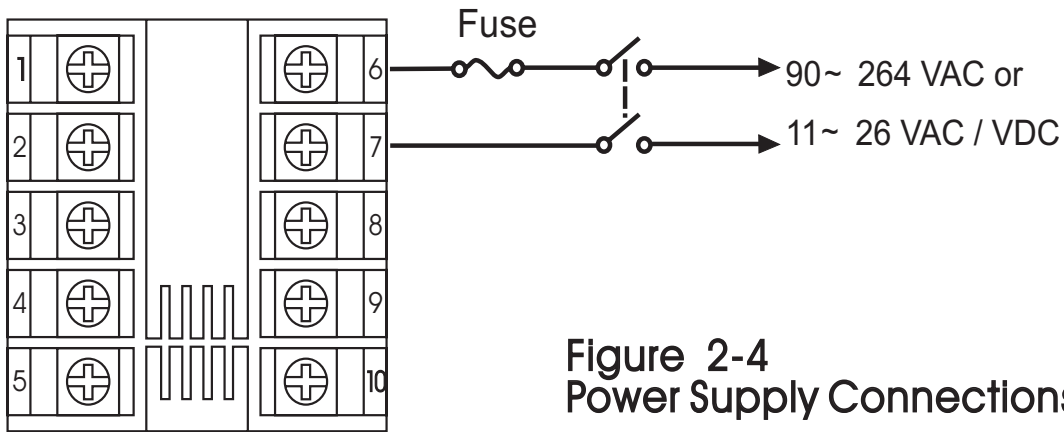

Figure 2-4
Power Supply Connections



This equipment is designed for installation in an enclosure which provides adequate protection against electric shock. The enclosure must be connected to earth ground.

Local requirements regarding electrical installation should be rigidly observed. Consideration should be given to prevent from unauthorized person access to the power terminals.

2-5 Sensor Installation Guidelines

Proper sensor installation can eliminate many problems in a control system. The probe should be placed so that it can detect any temperature change with minimal thermal lag. In a process that requires fairly constant heat output, the probe should be placed closed to the heater. In a process where the heat demand is variable, the probe should be closed to the work area. Some experiments with probe location are often required to find this optimum position.

In a liquid process, addition of a stirrer will help to eliminate thermal lag. Since the thermocouple is basically a point measuring device, placing more than one thermocouple in parallel will provide an average temperature readout and produce better results in most air heated processes.

Proper sensor type is also a very important factor to obtain precise measurements. The sensor must have the correct temperature range to meet the process requirements. In special processes the sensor might need to have different requirements such as leak-proof, anti-vibration, antiseptic, etc.

Standard thermocouple sensor limits of error are ± 4 degrees F (± 2 degrees C) or 0.75% of sensed temperature (half that for special) plus drift caused by improper protection or an over-temperature occurrence. This error is far greater than controller error and cannot be corrected at the sensor except by proper selection and replacement.

2-6 Thermocouple Input Wiring

Thermocouple input connections are shown in Figure 2-5. The correct type of thermocouple extension lead-wire or compensating cable must be used for the entire distance between the unit and the thermocouple, ensuring that the correct polarity is observed throughout. Joints in the cable should be

If the length of thermocouple plus the extension wire is too long, it may affect the temperature measurement. A 400 ohms K type or a 500 ohms J type thermocouple lead resistance will produce approximately 1 degree C temperature error .

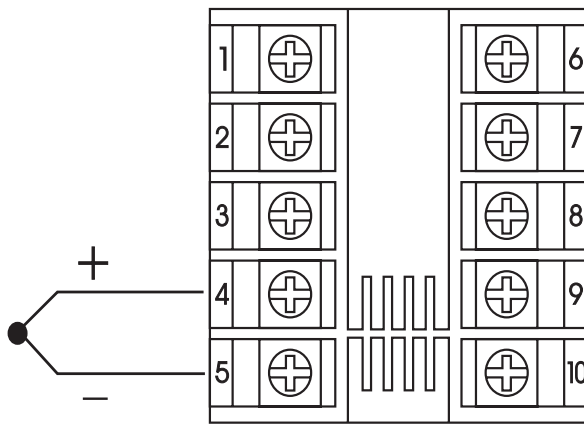
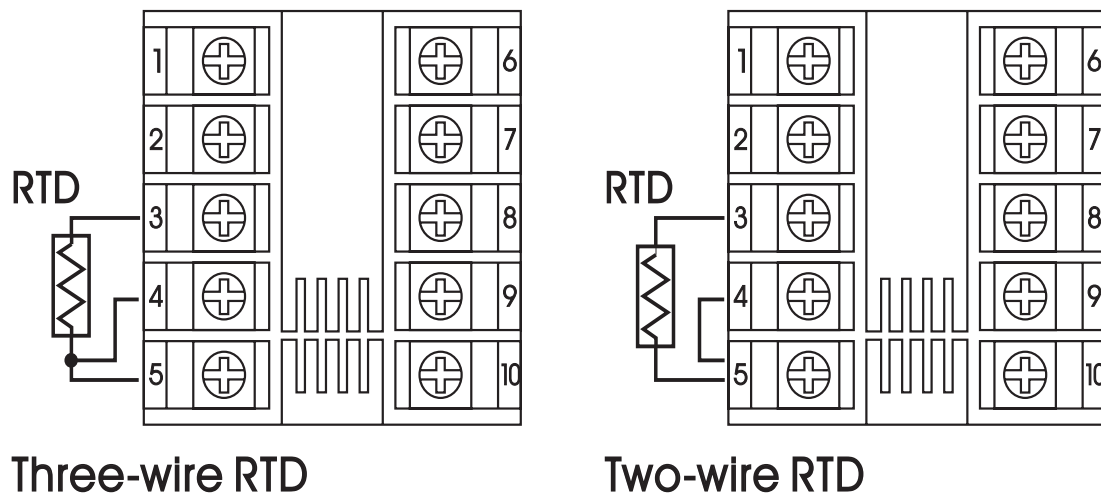

Figure 2.5
Thermocouple Input Wiring

2-7 RTD Input Wiring

RTD connections are shown in Figure 2-6, with the compensating lead connected to terminal 4. For two-wire RTD inputs, terminals 4 and 5 should be linked. The three-wire RTD offers the capability of lead resistance compensation provided that the three leads are of same gauge and equal length.

Two-wire RTD should be avoided, if possible, for the purpose of accuracy. A 0.4 ohm lead resistance of a two-wire RTD will produce 1 degree C temperature error.



Three-wire RTD

Two-wire RTD

Figure 2-6
RTD Input Wiring

2-8 Linear DC Input Wiring

DC linear voltage and linear current connections are shown in Figure 2-7 and Figure 2-8 .

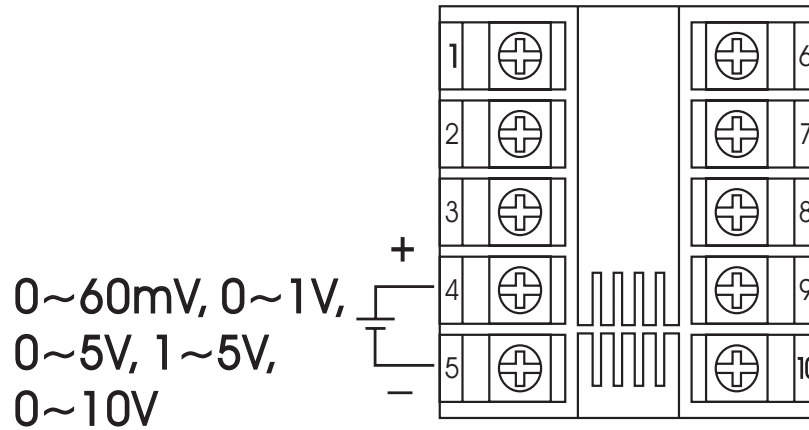

Figure 2.7
Linear Voltage Input Wiring *

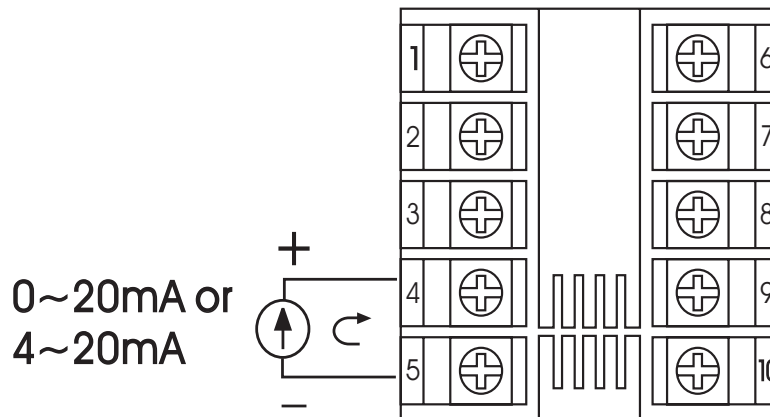
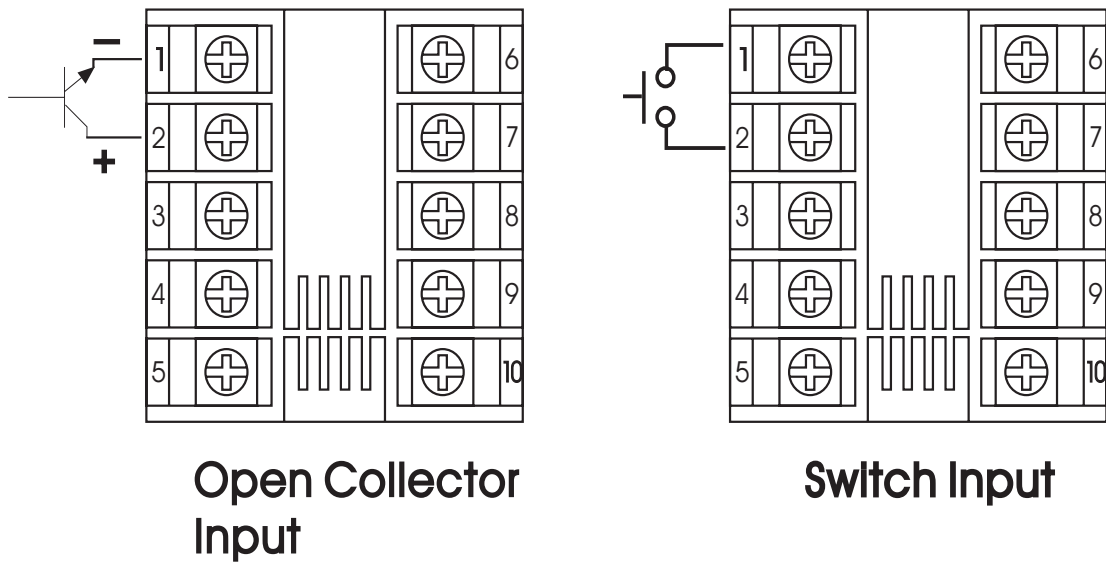

Figure 2.8
Linear Current Input Wiring *

NOTE: Volt and Milliamp inputs are NOT FM Approved.

2-9 Event Input wiring

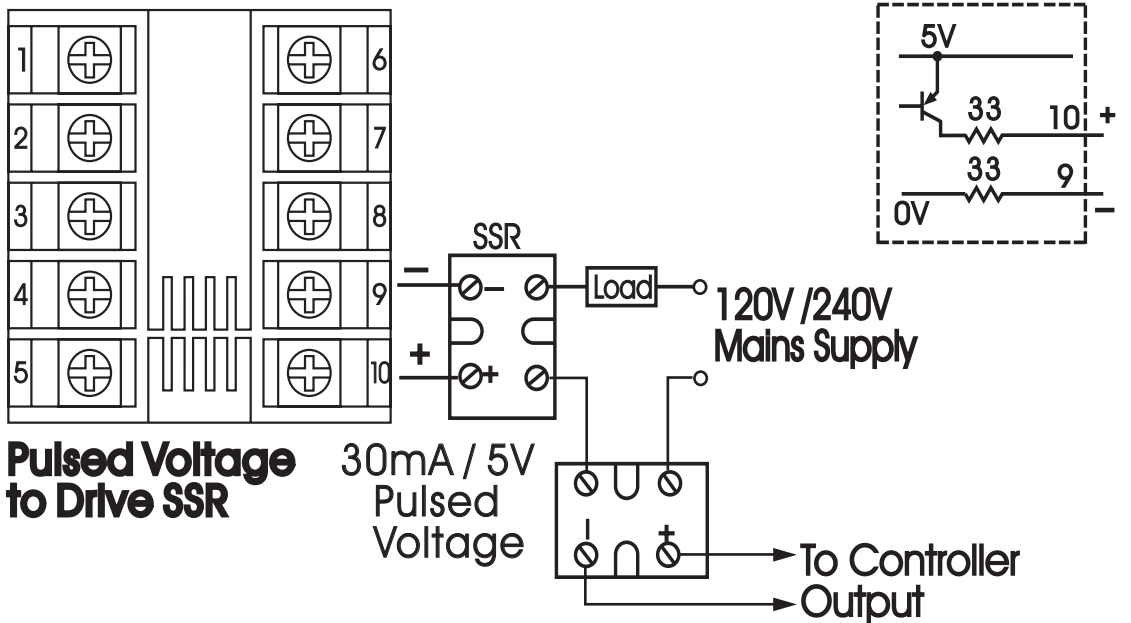
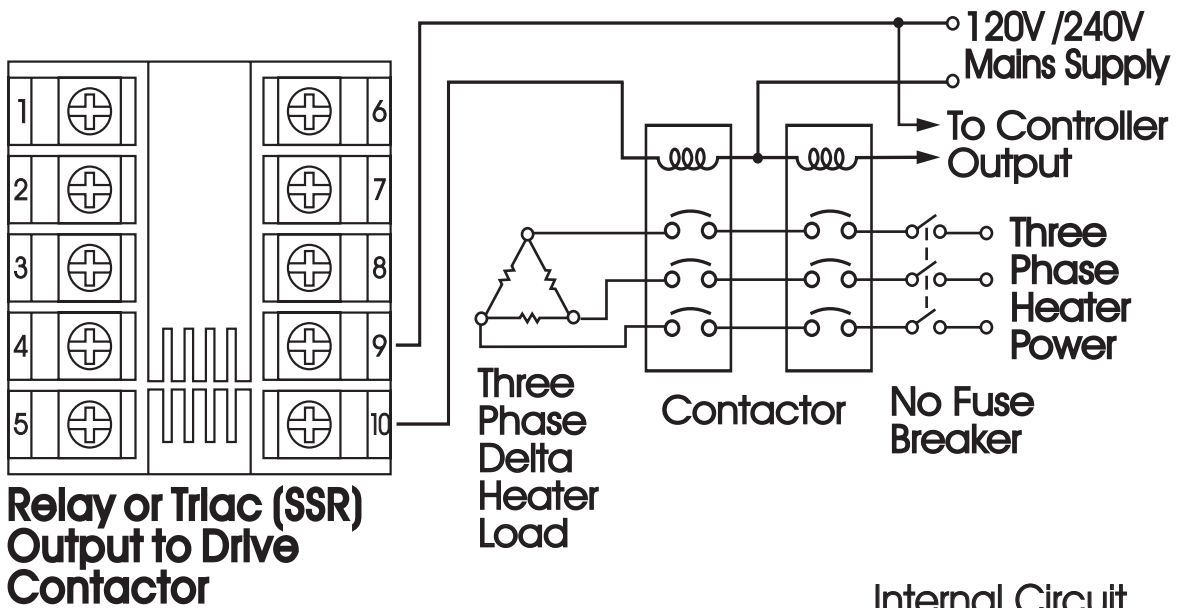
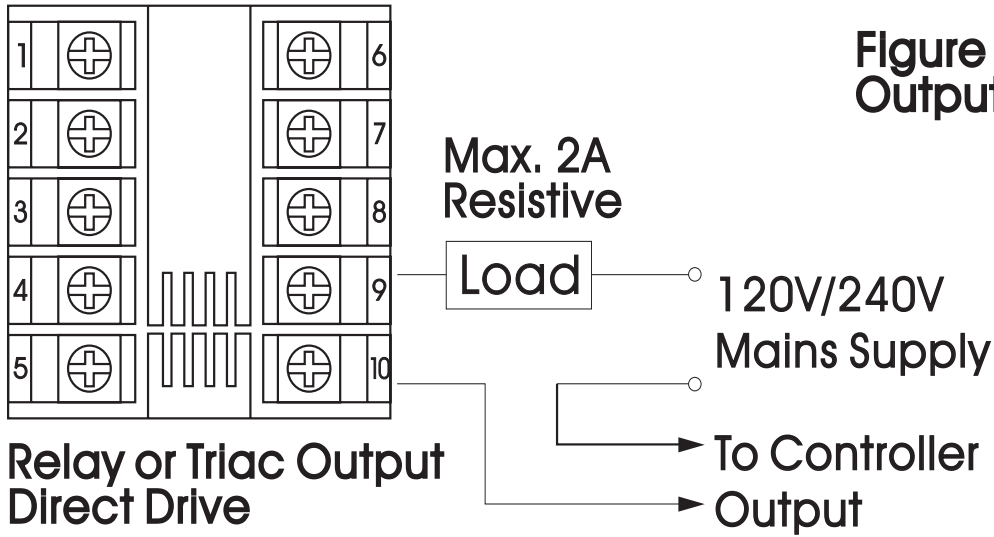

**Figure 2-9
Event Input Wiring**

The event input can accept a switch signal as well as an open collector signal. The event input function (EIFN) is activated as the switch is closed or an open collector (or a logic signal) is pulled down.

2-10 Output 1 Wiring

Figure 2-10
Output 1 Wiring



2-11 Output 2 Wiring

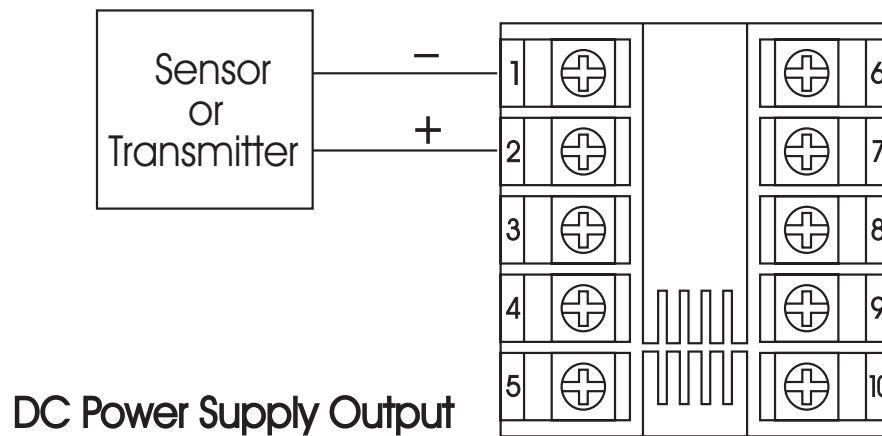
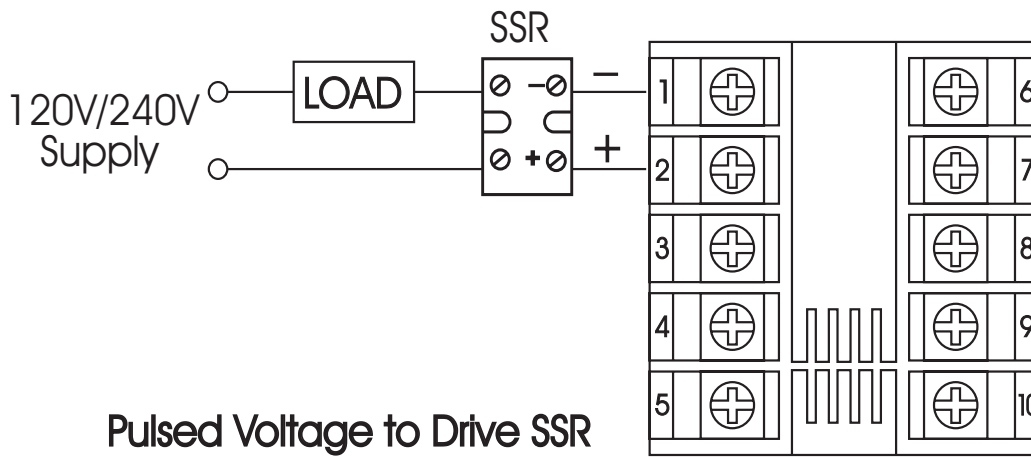
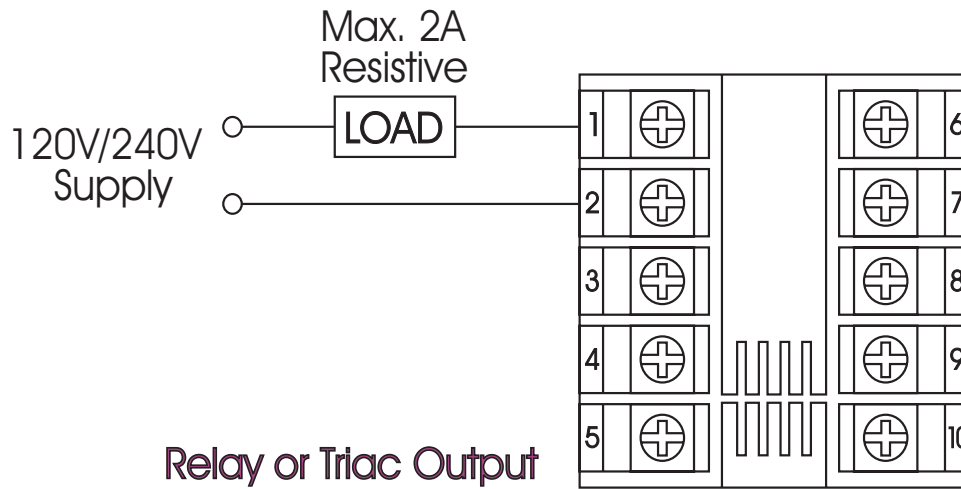

Figure 2-11 Output 2 Wiring

2-12 RS-485

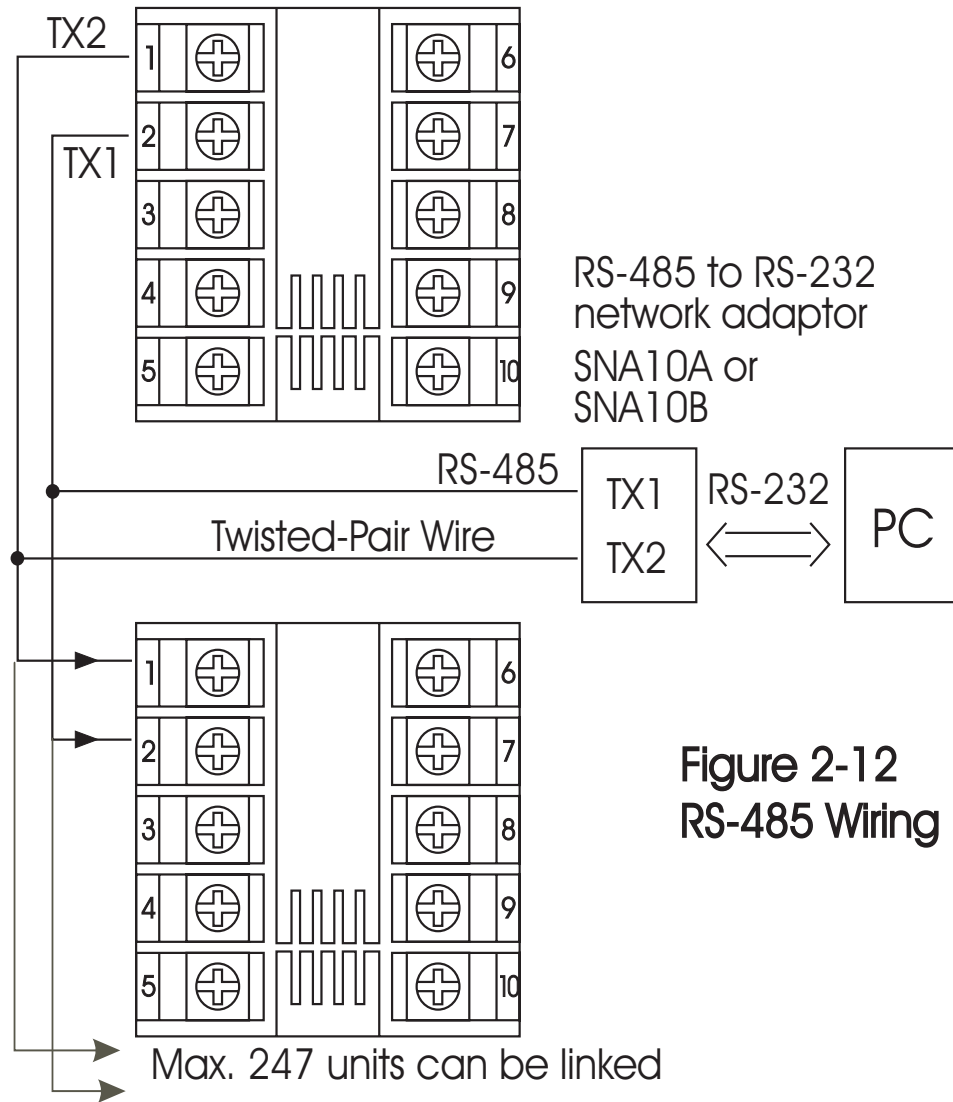
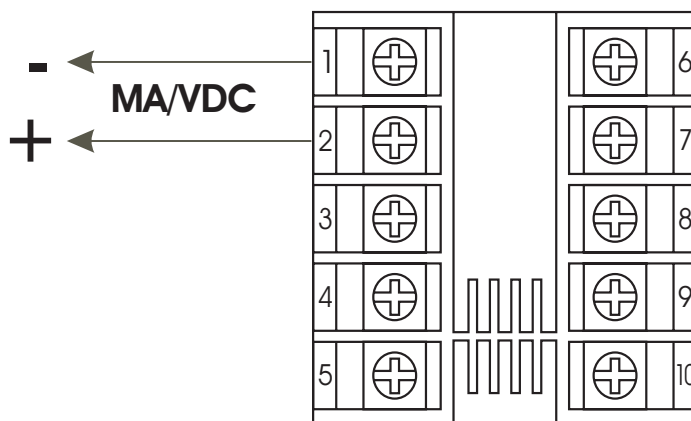

Figure 2-12
RS-485 Wiring



2-13 Retransmission Output

Output options include: Ma and VDC



Chapter 3 Programming

3-1 Process Input

Press  for 4 seconds to enter setup mode. Press  to select the parameter. The display will indicate the parameter symbol and the value (or selection) for that parameter.

INPT: Selects the sensor type and signal type for the process input.

UNIT: Selects the process unit.

RESO: Selects the location of the decimal point (Resolution) for most (not all) process related parameters.

IN.LO: Selects the low scale value for the Linear type input
Hidden if: T/C or RTD type is selected for INPT

IN.HI: Selects the high scale value for the Linear type input
Hidden if: T/C or RTD type is selected for INPT

How to use IN.LO and IN.HI:

If 4-20mA is selected for INPT, let SL specifies the input signal low (ie. 4mA), SH specifies the signal high (ie. 20mA), S specifies the current input signal value, the conversion curve of the process value is shown as follows:

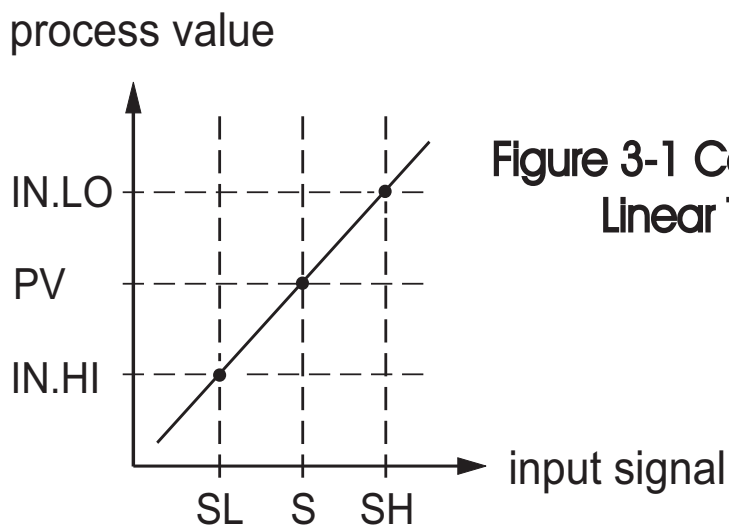

Figure 3-1 Conversion Curve for Linear Type Process Value

Formula: $PV = IN.LO + (IN.HI - IN.LO) \frac{S-SL}{SH-SL}$

Example: a 4-20 mA current loop pressure transducer with range 0 - 15 kg/cm² is connected to input, then perform the following setup:

INPT = 4-20 mA IN.LO = 0.0
UNIT = PU IN.HI = 15.0
RESO = 1-DP

Of course, you may select other value for RESO to alter the resolution.

3-2 Limit Control

O1.HY: Output 1 hysteresis value. The hysteresis value is adjusted to a proper value to eliminate the relay jitter in a noisy environment.

3-3 Set Point Range

HSP.L : Lower limit of HSP1
Hidden if LO is selected for OUT1

HSP.H : Upper limit of HSP1
Hidden if LO is selected for OUT1

LSP.L : Lower limit of LSP1
Hidden if HI is selected for OUT1

LSP.H : Upper limit of LSP1
Hidden if HI is selected for OUT1

HSP.L and HSP.H in setup menu are used to confine the adjustment range of HSP1. LSP.L and LSP.H are used to confine the adjustment range of LSP1.

3-4 PV Shift

In certain application it is desirable to shift the indicated value from its actual value. This can be easily accomplished with this unit by using the PV shift function.

Cycle the unit to the SHIF parameter by using the scroll key. The number you adjust here, either positive or negative, will be added to the actual value. The SHIF function will **alter PV**

SHIF: PV shift (input correction) value

3-5 Digital Filter

In certain applications the process value is too unstable to be read. To Improve this a programmable low pass filter incorporated in the L91 can be used. This is a first order filter with time constant specified by FILT parameter which is contained in setup menu. The FILT is defaulted to 0.5 sec. before shipping. Adjust FILT to change the time constant from 0 to 60 seconds. 0 second represents no filter is applied to the input signal. The filter is characterized by the following diagram.

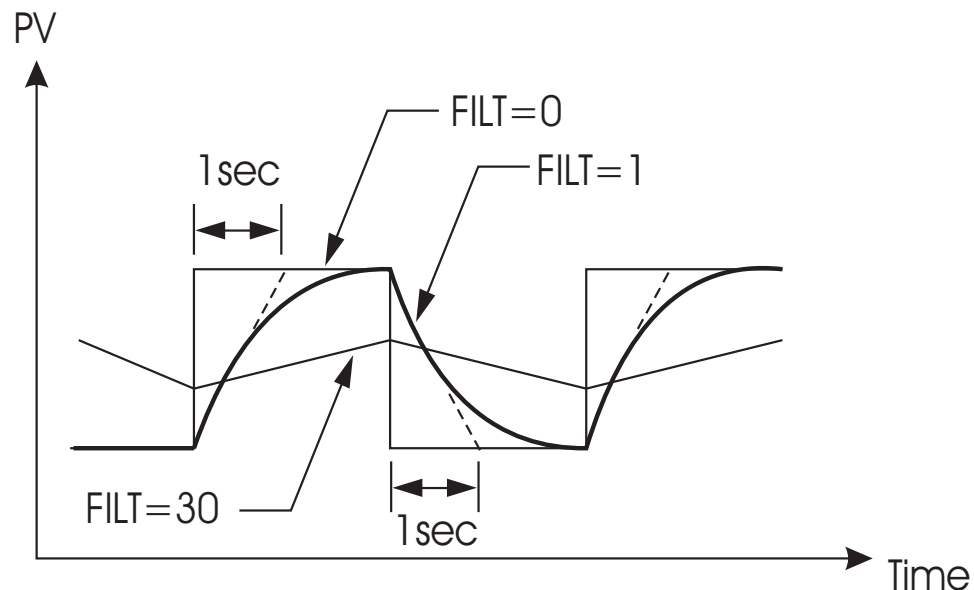

Figure 3-2 Filter Characteristics

3-6 Process Alarms

The output 2 will perform process alarm function by selecting ALM for OUT2 and PV.H.A or PV.L.A for AL.FN. If PV.H.A is selected the alarm will perform process high alarm. If PV.L.A is selected the alarm will perform process low alarm. The process alarm sets an absolute trigger level. When the process exceeds that absolute trigger level an alarm occurs. The trigger level is determined by SP2 (Set point 2 value) and AL.HY (Alarm hysteresis value). The hysteresis value is introduced to avoid interference action of alarm in a noisy environment. Normally AL.HY can be set with a minimum value(0.1).

Trigger levels for process high alarm are SP2 and $SP2 - AL.HY$.
Trigger level for process low alarm are $SP2 + AL.HY$ and Sp2.

There are two types of alarm mode can be selected, these are: normal alarm and latching alarm.

Normal Alarm: AL.MD= NORM

When a normal alarm is selected, the alarm output is de-energized in the non-alarm condition and energized in an alarm **condition**.

Latching Alarm: AL.MD= LTCH

If a latching alarm is selected, once the alarm output is energized, it will remain unchanged even if the alarm condition has been cleared unless the power is shut off or the RESET key (or remote reset button) is pressed.

Failure Transfer: AL.FT = OFF or ON

In case of **Sensor Break** or **A-D Failure** occurs, the alarm output will be on or off according to the selection of AL.FT.

Examples:

SP2 = 200	AL.HY = 10.0
AL.MD = NORM	AL.FN = PV.H.A

Examples:

Process proceeds →

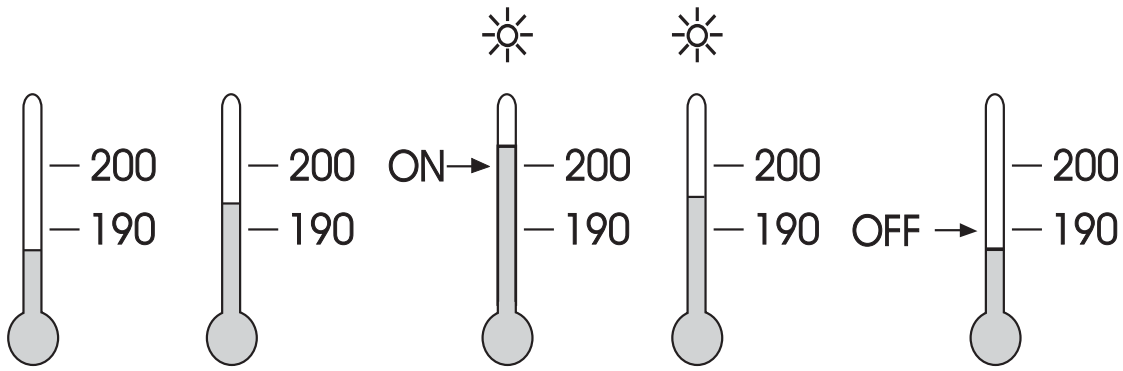
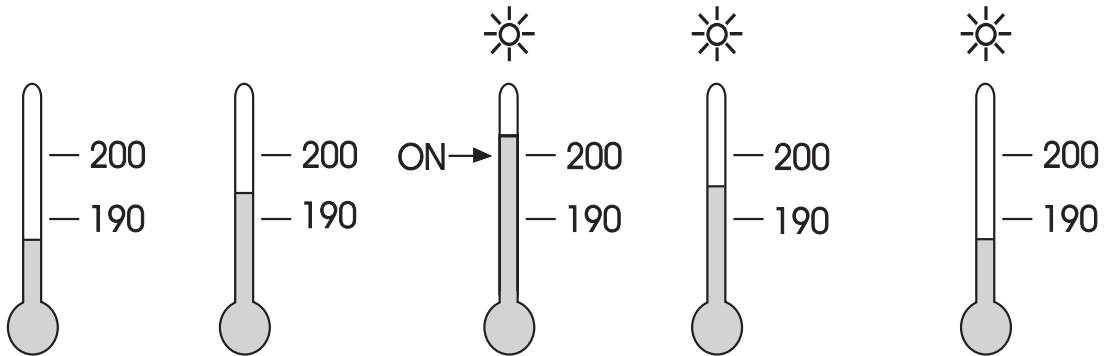

Figure 3.3
Normal Process Alarm

SP2 = 200 AL.HY = 10.0
AL.MD = LTCH AL.FN = PV.H.A

Figure 3.4
Latching Process Alarm

Process proceeds →



3-7 RS-485 Communication

Using a PC for data communication is the most economic way. The signal is transmitted and received through the PC communication Port (generally RS-232). Since a standard PC can't support RS-485 port, a network adaptor (such as SNA10A, SNA10B) has to be used to convert RS-485 to RS-232 for a PC if RS-485 is required for the data communication. Many RS-485 units (up to 247 units) can be connected to one RS-232, that is a PC with 4 comm ports can communicate with 988 units.

Select COMM for OUT2 in setup menu, the output 2 will perform RS-485 interface with **Modbus RTU Mode** protocol.

Setup

1. Select COMM for OUT2
2. Set an unequal address (ADDR) for those units which are connected to the same port.
3. Set the Baud Rate (BAUD) and Parity Bit (PARI) such that these values are accordant with PC setup conditions.

3-8 Display Mode

The DISP in the setup menu is used to select the display format for the normal condition. If PV is selected, the display will indicate the process value. If SP1 is selected, the display will indicate HSP1 value for high limit control (OUT1 = HI) and high/low limit control (OUT1 = HI.LO) or indicate LSP1 value for low limit control (OUT1 = LO). IF SAFE is selected, the display will indicate the word SAFE for the normal condition.

However the display will indicate the process value if the process value goes beyond high limit or low limit. If an error condition occurs, the display will indicate the error symbol. The SAFE display will return when the process has returned to within SAFE values. Depressing reset key will reset output relay.

3-9 Signal Conditioner DC Power Supply

Three types of isolated DC power supply are available to supply an external transmitter or sensor. These are 20V rated at 25mA, 12V rated at 40 mA and 5V rated at 80 mA. The DC voltage is delivered to the output 2 terminals by selecting DCPS for OUT2 in setup menu.

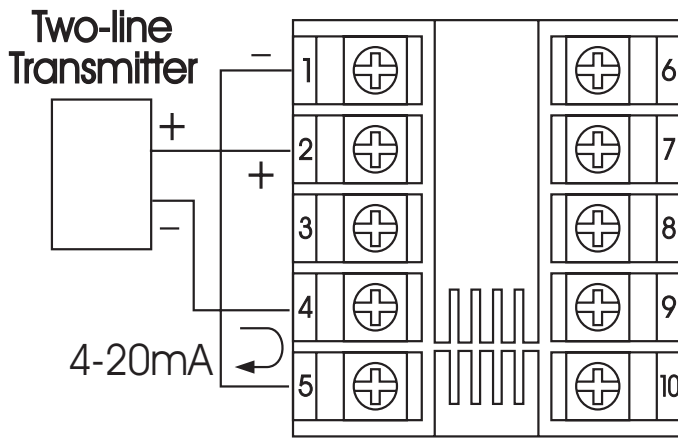

Set
OUT2 = dCPS
 DC Power Supply

Figure 3-5
 DC Power Supply
 Application

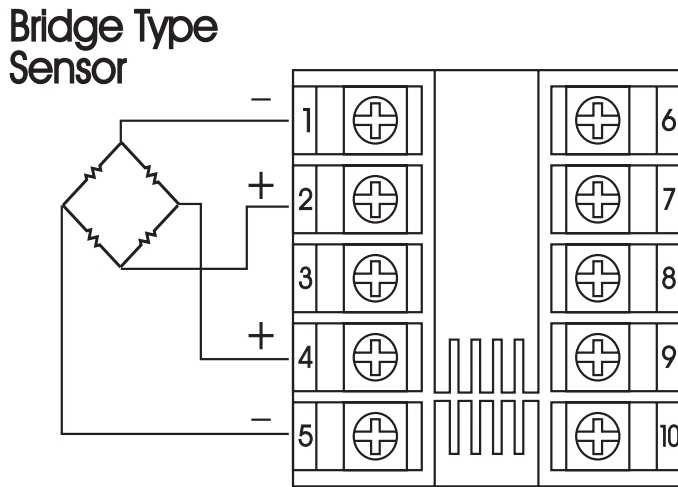
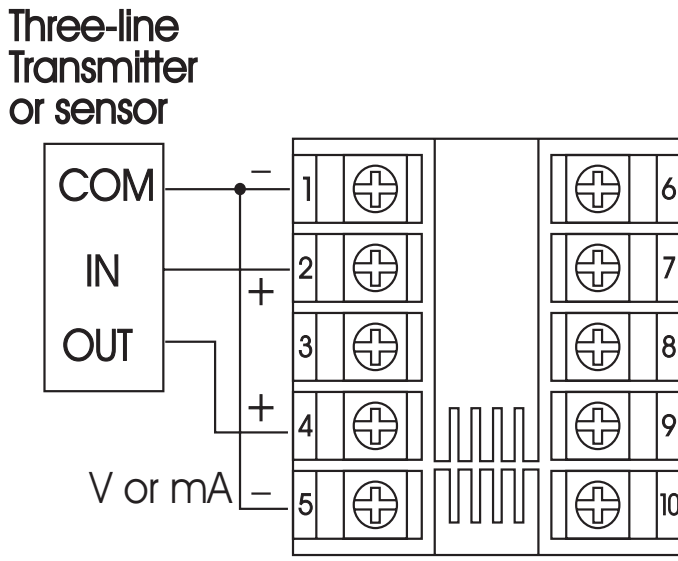

Caution:
 Don't use the DC power supply beyond its rating current to avoid damage.
 Purchase a correct voltage to suit your external devices. See ordering code in section 1-2.

3-10 Remote Reset

If EIFN is selected for OUT2 and REST is selected for EIFN, terminals 1 & 2 will act as remote reset input. Pressing remote reset button will perform the same function as pressing the RESET key. Refer to **section 1-4** for RESET key function.

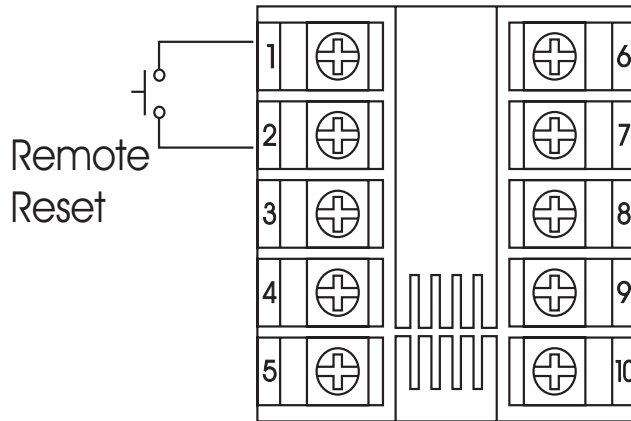

Setup

OUT2 = EIFN

EIFN = REST

Figure 3-6 Remote Reset Application

3-11 Remote Lock

If EIFN is selected for OUT2 and LOCK is selected for EIFN, terminals 1 & 2 will act as remote lock input. Turning the remote lock switch on will keep all the parameter setting from been changed.

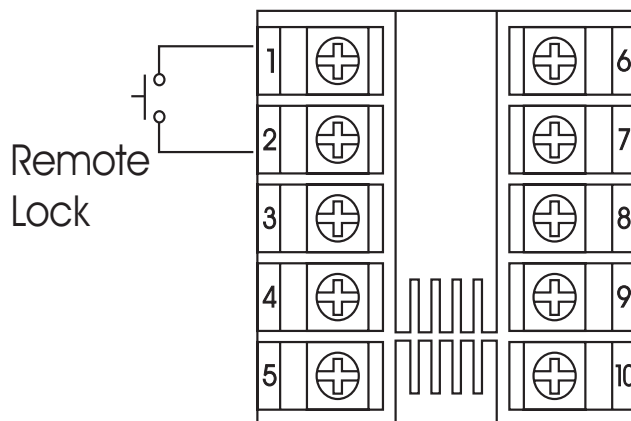

Setup

OUT2 = EIFN

EIFN = LOCK

Figure 3-7 Remote Lock Application

3-12 Limit Annunciator

If L_AN (Limit annunciator) is selected for OUT2, the output 2 will act as a Limit Annunciator. If the limit is or has been reached and the RESET key (or remote reset contacts) has not been pressed since the limit was reached, then the limit annunciator output will be energized and the OP2 indicator will be lit and remain unchanged until the RESET key or remote reset input is applied.

3-13 Reference Data

There are three reference data contained in setup menu. The reference data are read only data. The maximum historical PV, displayed by *PV.HI*, which shows the maximum process value since the last UNLOCK operation. The minimum historical PV, displayed by *PV.LO*, which shows the minimum process value since the last UNLOCK operation. The abnormal time, displayed by *T.ABN*, which shows the total accumulated time (minutes) during the process has been in abnormal condition since the last UNLOCK operation.

The values of reference data will be initiated as soon as the RESET key is pressed for 4 seconds (UNLOCK operation). After UNLOCK operation, the PV.HI and PV.LO values will start from the current process value and T.ABN value will start from zero.

Chapter 4 Application

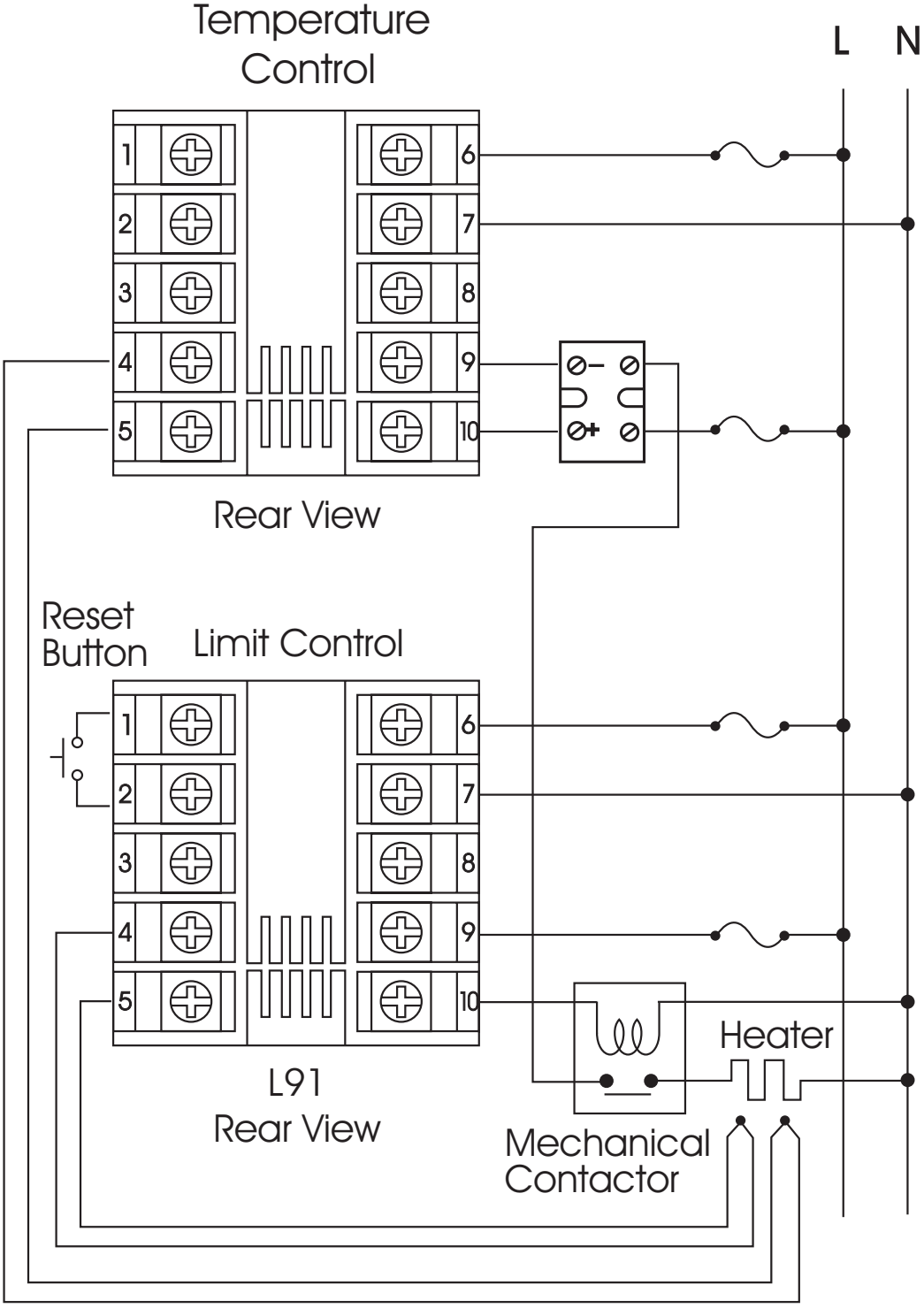

Figure 4-1 Over Temperature Protection with Remote Reset

Chapter 5 Calibration



Do not proceed through this section unless there is a definite need to re-calibrate the controller. Otherwise, all previous calibration data will be lost. Do not attempt re-calibration unless you have appropriate calibration equipment. If calibration data is lost, you will need to return the unit to your supplier who may charge you a service fee to re-calibrate the unit.



Entering calibration mode will break the control loop. Make sure that if the system is allowable to apply calibration mode.

Equipment needed for calibration:

- (1) A high accuracy calibrator (Fluke 5520A Calibrator recommended) with following function:
 - 0-100mA millivolt source with +/-0.005% accuracy
 - 0-10V voltage source with +/-0.005% accuracy
 - 0-20mA current source with +/-0.005% accuracy
 - 0-300 ohm resistant source with +/-0.005% accuracy
- (2) A test chamber providing 25°C - 50°C temperature range
- (3) A switching network (SCANNER 80, optional for automatic calibration)
- (4) A calibration fixture equipped with programming units (optional for automatic calibration)
- (5) A PC with calibration software FD-Net and Smart Network Adaptor SNA10B (optional for automatic calibration)

Since each unit needs 30 minutes to warm up before calibration.

The calibration procedures described in the following are a step by step **manual procedures**.

Apply Enter Key (press  for 8 seconds) to enter the calibration mode. see **Figure 5-1**.

Figure 5-1
Flow Chart for Manual
Calibration

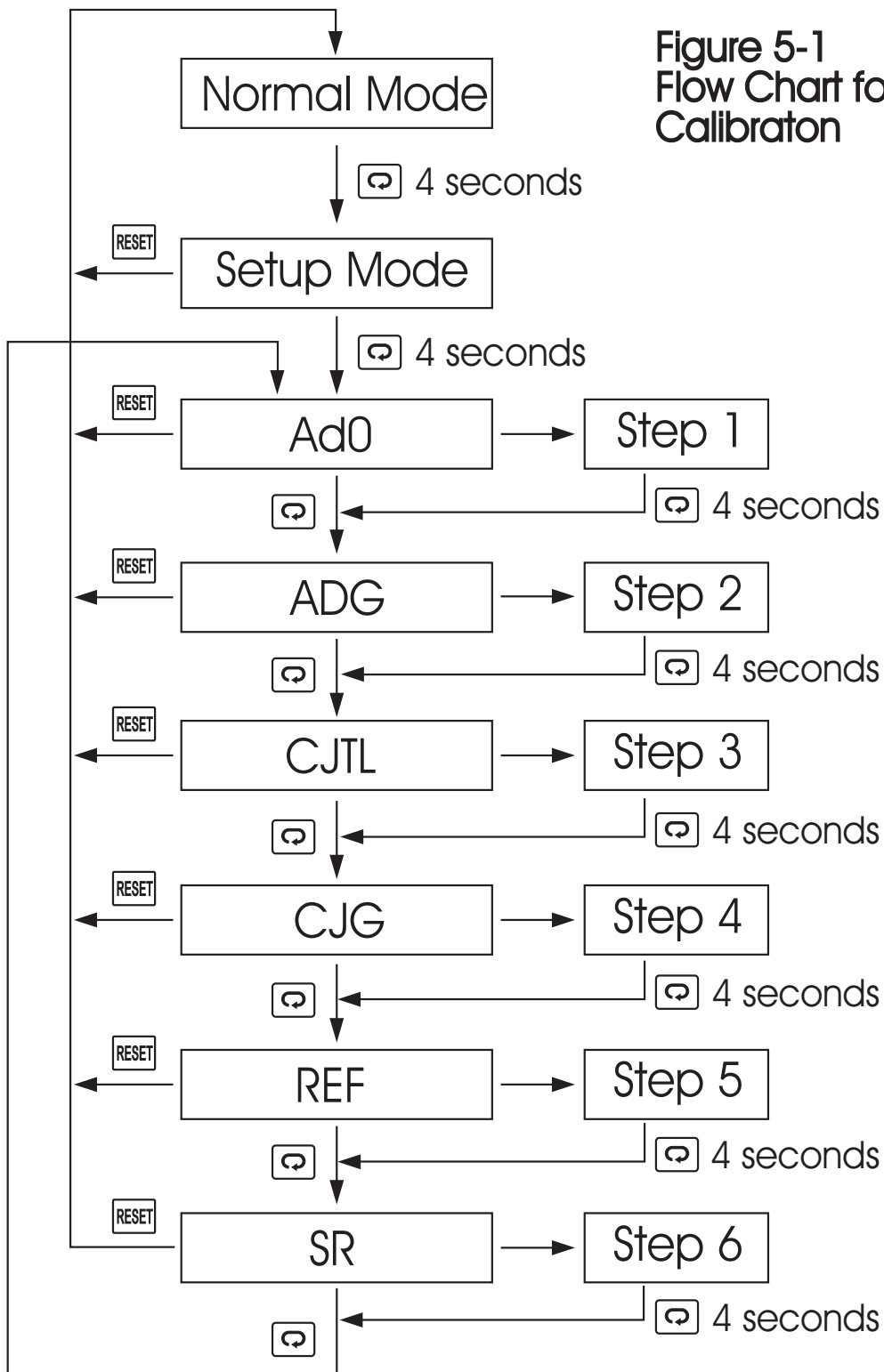

Step1: Calibrate **Zero** of A to D converter.

Short terminal 4 and 5, then press  for at least 4 seconds. The display will blink a moment. If the display didn't blink, then the calibration has failed.

Step 2: Calibrate **Gain** of A to D converter.

Send a span signal to terminal 4 and 5 with correct polarity. The span signal is 60 mV for thermocouple input, 1V for 0-1V input, 10V for 0-10V input and 20mA for 0-20 mA input. Press  for at least 4 seconds. The display will blink a moment. If the display didn't blink, then the calibration failed.

Step 3: Calibrate **offset** of **cold junction**.

Setup the equipment according to the following diagram for calibrating the cold junction compensation. Note that a K type thermocouple must be used.

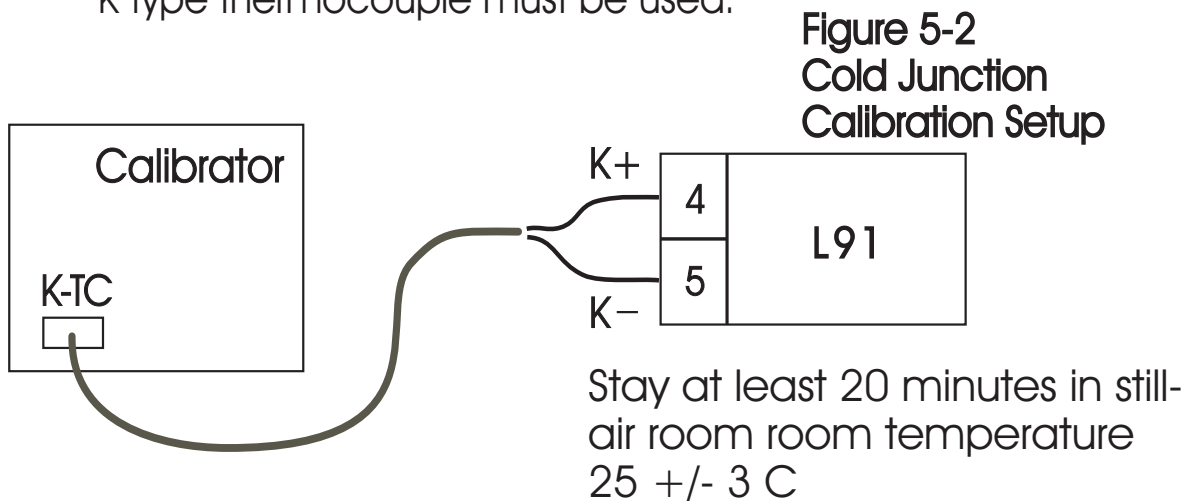

NOTE: The unit under calibration is powered in a still-air room at a temperature 25 +/-3 C. Allow at least 20 minutes for warming up.

The L91 being calibrated for Cold Junction Compensation MUST be programmed for K t/c input, Celsius display **prior** to performing the CJTL calibration.

Set the calibrator to be configured as K type thermocouple output. Calibrator must have an internal compensation. Send a 0.00 C signal to the unit under calibration.

With CJTL on the display adjust the value to 0.00 reading. Once adjusted, Press  for at least 4 seconds. The display will blink a moment. If the display didn't blink, then the calibration failed.

Step 4: Calibrate **gain of cold junction.**

Setup the equipment same as step 3.

NOTE: The unit under calibration must powered at an ambient temperature of 50C +/-3. Allow at least 20 minutes for warming up.

The L91 being calibrated for Cold Junction Compensation MUST be programmed for K t/c input, Celsius display **prior** to performing the CJG calibration.

Set the calibrator to be configured as K type thermocouple output. Calibrator must have an internal compensation.

Send a 0.00 C signal to the unit under calibration.

With CJG on the display adjust the value to 0.00 reading.

Once adjusted, Press  for at least 4 seconds. The display will blink a moment. If the display didn't blink, then the calibration failed.

Step 5: Calibrate **RTD reference voltage.**

Send a 100 ohms signal to terminal 3, 4 and 5 according to

Figure 5-3.

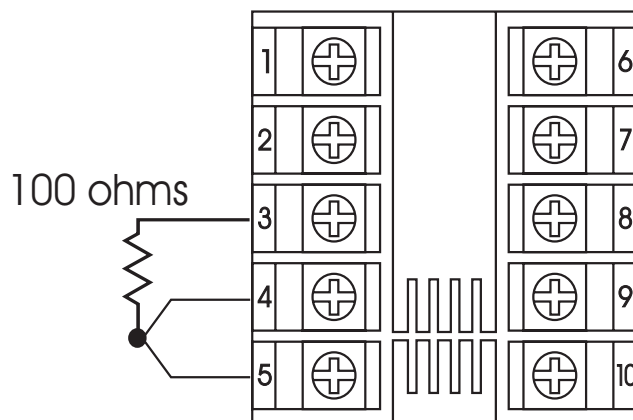



Figure 5-3
RTD Calibration

Press  for at least 4 seconds. The display will blink a moment. If the display didn't blink, then the calibration failed.

Step 6: Calibrate **RTD serial resistance.**

Change the ohm's value of the calibrator to 300 ohms. Press

 for at least 4 seconds. The display will blink a moment. If the display didn't blink, then the calibration failed.

Chapter 6 Specifications

Power

90-264 VAC, 49-63 Hz, 10 VA, 5W maximum

11-26 VAC/VDC, 10 VA, 5W maximum

Input

Resolution: 18 bits

Sampling: 5 times/second

Maximum Rating: -2 VDC minimum, 12 VDC maximum
(1 minute for mA input)

Temperature Effect: $1.5 \mu\text{V} / ^\circ\text{C}$

Sensor Lead Resistance Effect:

T/C: $0.2 \mu\text{V}/\text{ohm}$

3-wire RTD: $2.6 ^\circ\text{C}/\text{ohm}$ of resistance difference of two leads

2-wire RTD: $2.6 ^\circ\text{C}/\text{ohm}$ of resistance sum of two leads

Burn-out Current: 200nA

Common Mode Rejection Ratio (CMRR): 120db

Sensor Break Detection:

Sensor open for TC, RTD and mV inputs,
below 1 mA for 4-20 mA input,
below 0.25V for 1-5 V input,
unavailable for other inputs.

Sensor Break Responding Time:

Within 4 seconds for TC, RTD and mA inputs,
0.1 second for 4-20 mA and 1-5V inputs.

Data Communication

Interface : RS-485 (up to 247 units)

Protocol : Modbus Protocol RTU mode

Address : 1 - 247

Baud Rate : 0.3 ~ 38.4 Kbits/sec

Data Bits : 8 bits

Parity Bit : None, Even or Odd

Stop Bit : 1 or 2 bits

Communication Buffer : 50 bytes

Characteristics:

Type	Range	Accuracy @ 25 °C	Input Impedance
J	-120°C- 1000°C (-184°F - 1832°F)	+/-2 C	2.2 MΩ
K	-200°C- 1370°C (-328°F - 2498°F)	+/-2 C	2.2 MΩ
T	-250°C- 400°C (-418°F - 752°F)	+/-2 C	2.2 MΩ
E	-100°C- 900°C (-148°F - 1652°F)	+/-2 C	2.2 MΩ
B	0°C- 1820°C (- 32°F - 3308°F)	+/-2 C (200°C- 1820°C)	2.2 MΩ
R	0°C- 1767.8°C (- 32°F - 3214°F)	+/-2 C	2.2 MΩ
S	0°C- 1767.8°C (- 32°F - 3214°F)	+/-2 C	2.2 MΩ
N	-250°C- 1300°C (-418°F - 2372°F)	+/-2 C	2.2 MΩ
L	-200°C- 900°C (-328°F - 1652°F)	+/-2 C	2.2 MΩ
PT100 (DIN)	-210°C- 700°C (-346°F - 1292°F)	+/-0.4 C	1.3 KΩ
PT100 (JIS)	-200°C- 600°C (-328°F - 1112°F)	+/-0.4 C	1.3 KΩ
mV	-8mV- 70mV	+/-0.05 %	2.2 MΩ
mA	-3mA- 27mA	+/-0.05 %	100 Ω
V	-1.3V- 11.5V	+/-0.05 %	510 KΩ

Table 6-1 Input Characteristics

Event Input

Logic Low: -10V minimum, 0.8V maximum.

Logic High: 2V minimum, 10V maximum.

Functions: Remote reset, remote lockout.

Output 1 / Output 2

Relay Rating: 2A/240 VAC, life cycles 200,000 for resistive load.

Pulsed Voltage: Source Voltage 5V, current limiting resistance
66 ohms.

Triac (SSR) Output

Rating: 1/240 VAC

Inrush Current: 20A for 1 cycle

Min. Load Current: 50 mA rms

Max. Off-state Leakage: 3 mA rms

Max. On-state Voltage: 1.5 V rms

Insulation Resistance: 1000 Mohms min. at 500 VDC

Dielectric Strength: 2500 VAC for 1 minute

DC Voltage Supply Characteristics (Installed at Output 2)

Type	Tolerance	Max. Output Current	Ripple Voltage	Isolation Barrier
20 V	+/-0.5 V	25 mA	0.2 Vp-p	500 VAC
12 V	+/-0.3 V	40 mA	0.1 Vp-p	500 VAC
5 V	+/-0.15 V	80 mA	0.05 Vp-p	500 VAC

Analog Retransmission

Functions: Process Variable

Output Signal: 4-20 mA, 0-20 mA, 0 - 5V, 1 - 5V, 0 - 10V

Resolution : 15 bits

Accuracy : +/-0.05 % of span +/-0.0025 %/ C

Load Resistance : 0 - 500 ohms (for current output)

10 K ohms minimum (for voltage output)

Regulation: 0.01 % for full load change

Settling Time: 0.1 sec. (stable to 99.9 %)

Breakdown Volts: 1000 VAC min.

Linearity Error : +/-0.005 % of span

Temp Effect: +/-0.0025 % of span / C

Saturation Low : 0 mA (or 0V)

Saturation High : 22.2 mA (or 5.55V, 11.1V min.)

Output Range :0-22.2mA(0-20mA or 4-20mA)

0-5.55V (0 - 5V, 1 - 5V)

0 - 11.1 V (0 - 10V)

User Interface

4-digit LED Displays: 0.4" (10mm),

Keypad: 4 keys

Programming Port: For automatic setup, calibration and testing.

Communication Port: Connection to PC for supervisory control.

Limit Control: High Limit, Low limit and High/Low Limit programmable

Digital Filter

Function: First order

Time Constant: 0, 0.2, 0.5, 1, 2, 5, 10, 20, 30, 60 seconds programmable

Environmental & Physical

Operating Temperature : -10°C to 50°C

Storage Temperature : -40° C to 60° C

Humidity : 0 to 90 % RH (non-condensing)

Insulation Resistance : 20 Mohms min. (at 500 VDC)

Dielectric Strength : 2000 VAC, 50/60 Hz for 1 minute

Vibration Resistance : 10 - 55 Hz, 10 m/s² for 2 hours

Shock Resistance : 200 m/s² (20 g)

Moldings : Flame retardant polycarbonate

Dimensions: 48 mm(W) X 48 mm(H) X 94 mm(D),
86 mm depth behind panel

Weight : 150 grams

Approval Standards

Safety : UL/cUR: QUYX2-QUYX8
FM, CE Approved

Protective Class :

IP30 front panel, indoor use,

IP 20 housing and terminals (with protective cover)

EMC EN61326

Warranty and Return Statement:

Warranty:

Future Design Controls products described in this brochure are warranted to be free from functional defects in material and workmanship at the time the products leave Future Design Controls facilities and to conform at that time to the specifications set forth in the relevant Future Design Controls manual, sheet or sheets for a period of TWO years after delivery to the first purchaser.

There are no expressed or implied Warranties extending beyond the Warranties herein and above set forth.

Limitations:

Future Design Controls provides no warranty or representations of any sort regarding the fitness of use or application of its products by the purchaser. Users are responsible for the selection, suitability of the products for their application or use of Future Design Controls products.

Future Design Controls shall not be liable for any damages or losses, whether direct, indirect, incidental, special, consequential or any other damages, costs or expenses excepting only the cost or expense of repair or replacement of Future Design Control products as described below.

Future Design Controls sole responsibility under the warranty, at Future Design Controls option, is limited to replacement or repair, free of charge, or refund or purchase price within the warranty period specified. This warranty does not apply to damage resulting from transportation, alteration, misuse or abuse.

Future Design Controls reserves the right to make changes without notification to purchaser to materials or processing that do not effect compliance with any applicable specifications.

Return Material Authorization:

Contact Future Design Controls for Return Material Authorization prior to returning any product to our facility.

Future Design Controls, Inc.

7524 West 98th Place, PO Box 1196, Bridgeview, IL 60455

888.751.5444 - Main Office

888.307.8014 - Fax

866.342.5332 - Technical Support

E-mail csr@futuredesigncontrols.com

Website www.futuredesigncontrols.com

State of California Proposition 65 Warning



Cancer and Reproductive Harm: This warning is intended to address certain Prop 65 chemicals that may be found in Future Design Controls products. These products can expose you to chemicals including lead and lead compounds which are known to the State of California to cause cancer, birth defects or other reproductive harm.

What is the state of California Proposition 65?

Proposition 65 requires businesses to provide warnings to Californians about significant exposures to chemicals that cause cancer, birth defects or other reproductive harm. These chemicals can be in the products that Californians purchase, in their homes or workplaces, or that are released into the environment. By requiring that this information be provided, Proposition 65 enables Californians to make informed decisions about their exposures to these chemicals.

For more information go to: www.P65Warnings.ca.gov

The most recent list of chemicals known to the State of California can be seen at:

<https://oehha.ca.gov/media/downloads/proposition-65//p65list102618.pdf>

Affected Products: This applies to all existing and future products offered by Future Design Controls.



LIMIT FDC-L91

Microprocessor Based Limit Controller

7524 West 98th Place
Bridgeview, IL 60455
Phone - 888-599-0103
Fax 708-599-1378
